

[123.98cm]
48 ¹³/₁₆"

[53.34cm]
21"

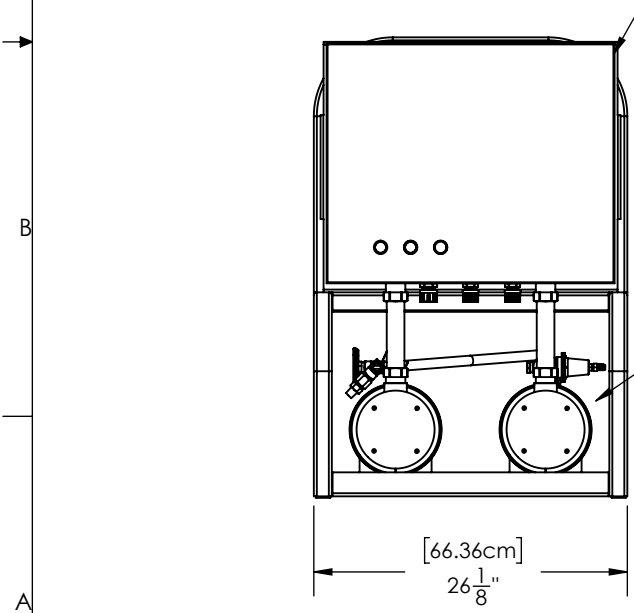

[66.36cm]
26 ¹/₈"

ELECTRICAL ENCLOSURE

HEATING ELEMENTS

NOTE:
MAINTENANCE REQUIRES 4' MIN. ON ELEMENT
HEAD SIDE AND 2' MIN. ON ALL OTHER SIDES

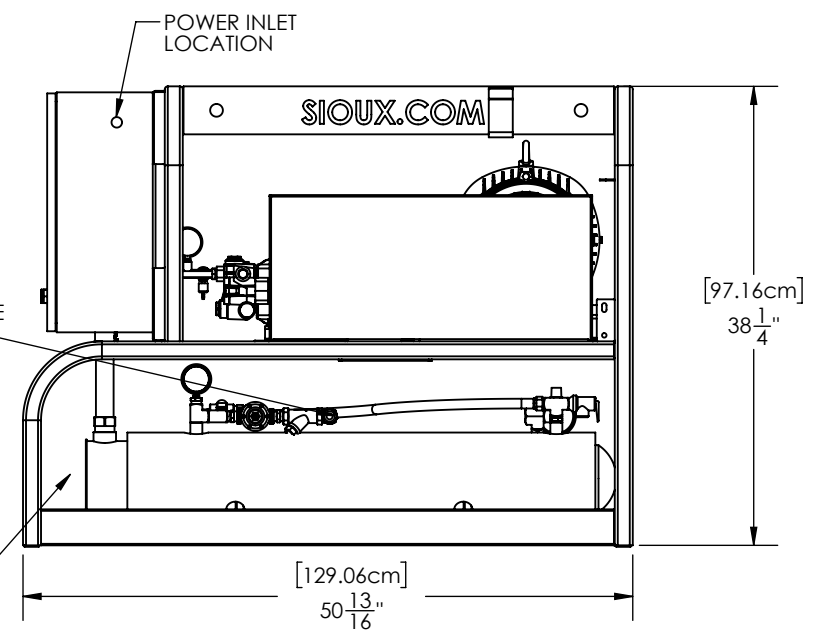

[97.16cm]
38 ¹/₄"

SIoux.COM

[129.06cm]
50 ¹³/₁₆"

APPLICABLE MACHINES		
MODEL	APPROX. WEIGHT	
	LB	KG
60HZ UNITS		
EN5.0H1200-60	650	295
EN5.0H1800-60	775	352
EN5.0H3000-60	800	363
EN7.1H1200-60	800	364
EN7.1H1800-60	825	375
EN7.1H3000-60	925	420
50HZ UNITS		
EN5.0H1200-50	650	295
EN5.0H1800-50	775	352
EN5.0H3000-50	800	364

NOTE: CASTERS ADD 8" (20.32cm) TO HEIGHT
SKID WILL ADD 6" (15.24cm) TO HEIGHT

Copyright © 2010 SIOUX CORPORATION. This information is property of Sioux Corporation, is subject to recall at any time, and is not to be used in any way detrimental to Sioux's interest. Use of material is subject to the Terms of Website Use listed on the www.siuox.com website.

PROPRIETARY AND CONFIDENTIAL THE INFORMATION CONTAINED IN THIS DRAWING IS THE SOLE PROPERTY OF SIOUX CORP. ANY REPRODUCTION IN PART OR AS A WHOLE WITHOUT WRITTEN PERMISSION OF SIOUX CORP IS PROHIBITED.	UNLESS NOTED: DIMENSIONS	DRN LN 4/24/14	SIOUX CORPORATION ONE SIOUX PLAZA, BERESFORD, SD 57004	
	INCHES	CHK		
	TOLERANCES	QC	THIRD-ANGLE PROJECTION	FR21121-W NON-XP #2 FRAME
	LINEAR: ±.0625 [1/16] ANGULAR: ±2°	SIZE A SCALE 1:16 FILE FR21121-W H-SERIES		REV A-05 SH 1/1

DWG NO: FR21121-W H-SERIES REV A-05 SHEET 1/1