

APPLICABLE MACHINES		
UNITS	APPROX. WEIGHT	
	LB	KG
60HZ UNITS		
EN0.8S250-60XP	725	330
EN2.0P1200-60XP	725	330
EN2.0P1800-60XP	775	352
EN2.0P3000-60XP	875	398
50HZ UNITS		
EN0.8S250-50XP	725	330
EN2.5P1200-50XP	725	330
EN2.5P1800-50XP	750	341
EN2.5P3000-50XP	800	364

**NOTE: CASTERS ADD 8" (20.32cm) TO HEIGHT
SKID WILL ADD 6" (15.24cm) TO HEIGHT**

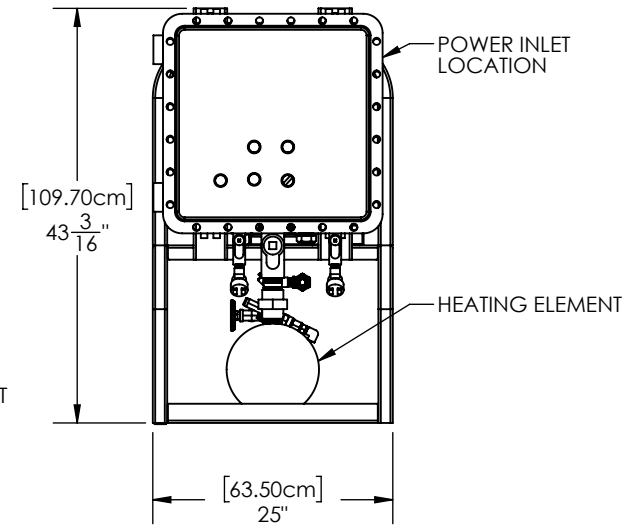
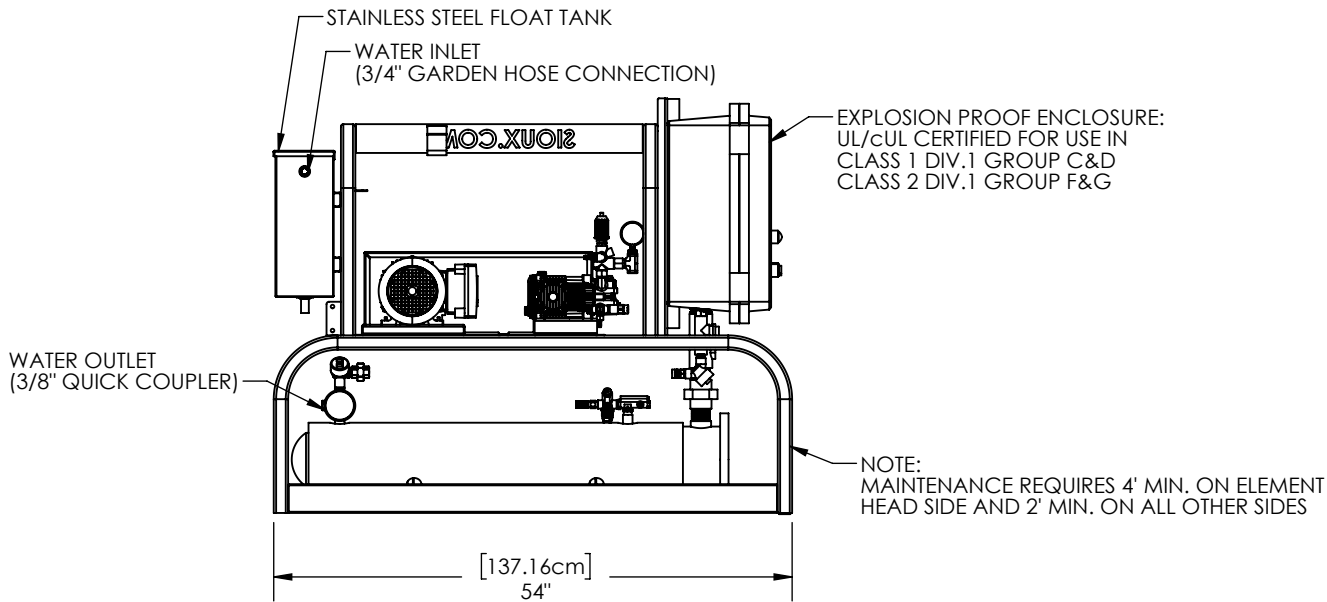

Copyright © 2010 SIOUX CORPORATION. This information is property of Sioux Corporation, is subject to recall at any time, and is not to be used in any way detrimental to Sioux's interest. Use of material is subject to the Terms of Website Use listed on the www.siuox.com website.

PROPRIETARY AND CONFIDENTIAL THE INFORMATION CONTAINED IN THIS DRAWING IS THE SOLE PROPERTY OF SIOUX CORP. ANY REPRODUCTION IN PART OR AS A WHOLE WITHOUT WRITTEN PERMISSION OF SIOUX CORP IS PROHIBITED.	UNLESS NOTED: DIMENSIONS	DRN LN 4/25/14	SIOUX CORPORATION ONE SIOUX PLAZA, BERESFORD, SD 57004			
	INCHES	CHK				EN-SERIES SINGLE ELEMENT P-SERIES XP MACHINES
	TOLERANCES	QC	THIRD-ANGLE PROJECTION	SIZE A	SCALE 1:24	FILE FR21122 XP #1 FRAME.FORWARD PLUMBED
	LINEAR: ±.0625 [1/16] ANGULAR: ±2°		FR21122-W P-SERIES	REV	A-05	SH 1/1

DWG NO. FR21122-W P-SERIES
 REV A-05
 SHEET 1/1