

APPLICABLE MACHINES		
MODEL	APPROX. WEIGHT	
	LB	KG
<b>60HZ UNITS</b>		
EN5.0H1200-60XP	900	409
EN5.0H1800-60XP	1125	511
EN5.0H3000-60XP	1150	523
EN7.1H1200-60XP	1150	523
EN7.1H1800-60XP	1175	534
EN7.1H3000-60XP	1300	591
<b>50HZ UNITS</b>		
EN5.0H1200-50XP	900	409
EN5.0H1800-50XP	1125	511
EN5.0H3000-50XP	1150	523

**NOTE: CASTERS ADD 8" (20.32cm) TO HEIGHT  
SKID WILL ADD 6" (15.24cm) TO HEIGHT**

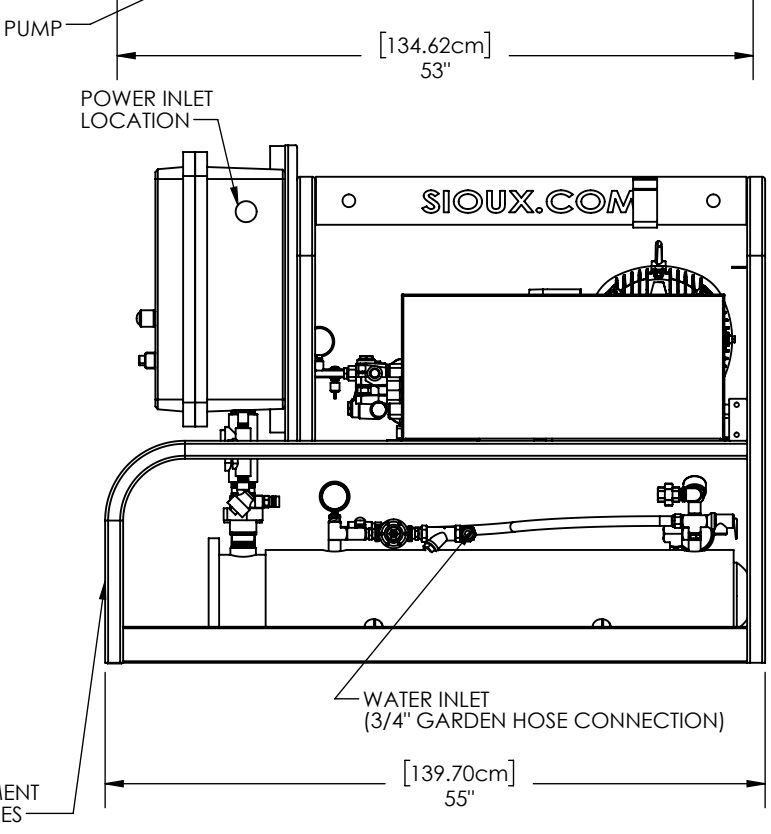
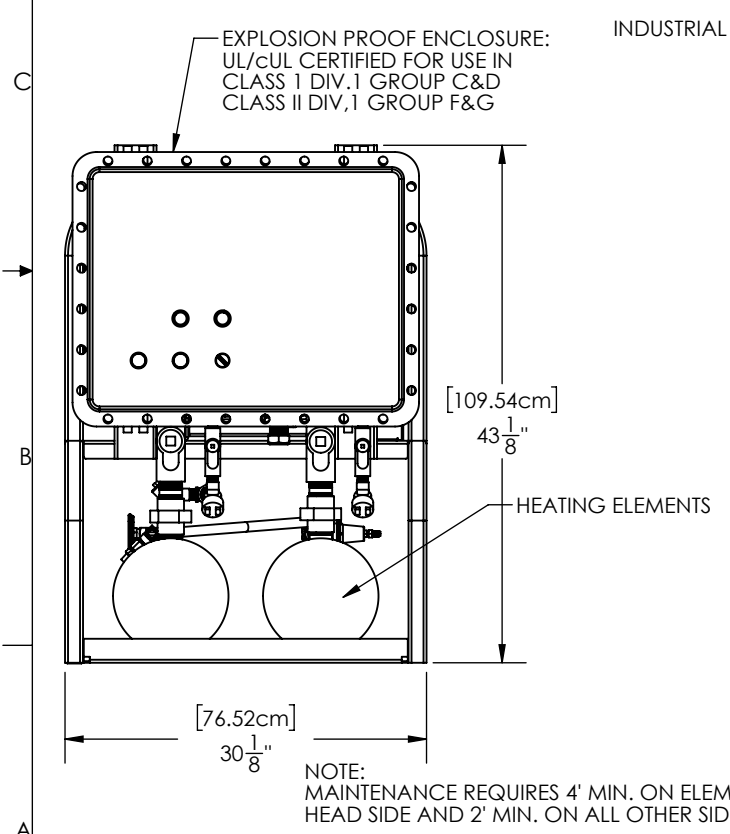

Copyright © 2010 SIOUX CORPORATION. This information is property of Sioux Corporation, is subject to recall at any time, and is not to be used in any way detrimental to Sioux's interest. Use of material is subject to the Terms of Website Use listed on the www.sioux.com website.

**PROPRIETARY AND CONFIDENTIAL**  
THE INFORMATION CONTAINED IN THIS DRAWING IS THE SOLE PROPERTY OF SIOUX CORP. ANY REPRODUCTION IN PART OR AS A WHOLE WITHOUT WRITTEN PERMISSION OF SIOUX CORP IS PROHIBITED.

UNLESS NOTED: DIMENSIONS IN INCHES  
TOLERANCES  
LINEAR: ±.0625 (1/16)  
ANGULAR: ±2°

DRN LN 4/28/14		<b>SIoux CORPORATION</b> ONE SIOUX PLAZA, BERESFORD, SD 57004	<b>EN-SERIES DUAL ELEMENT H-SERIES XP MACHINES</b>	SCALE 1:16 FILE
CHK				

DWG NO. FR21123 H-SERIES  
 REV A-05  
 SHEET 1/1