

MODEL	APPROX. WEIGHT	
	LB	KG
SF50D - TM (DRY)	6000	2750
SF50D - TM (WET)	9750	4450

WHEELS: STEEL 15" X 6"
 6 BOLT 5.5" B.C.
 TIRES: 225-75-15 C-RATED
 AXLE: DOUBLE 5200#
 SPIRINGS: SLIPPER LEAF SPRINGS
 BRAKES: ELECTRIC DRUM
 PLUG: 7-WAY FLAT BLADE
 GVWR: 10400 LBS

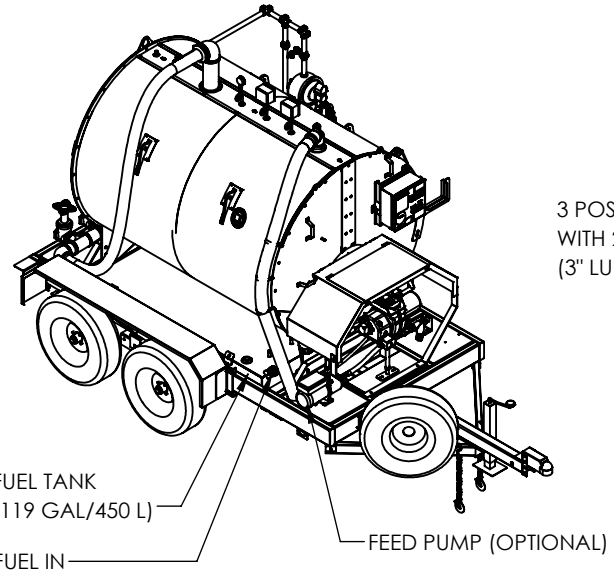

3 POSITION ADJUSTABLE MOUNT WITH 2-5/16" BALL MOUNT (3" LUNETTE EYE AVAILABLE)

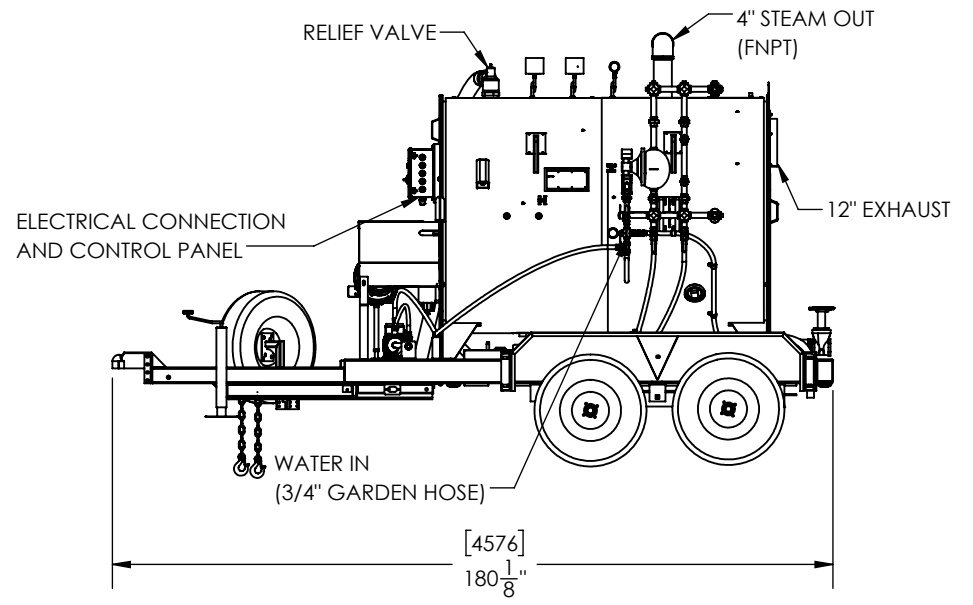
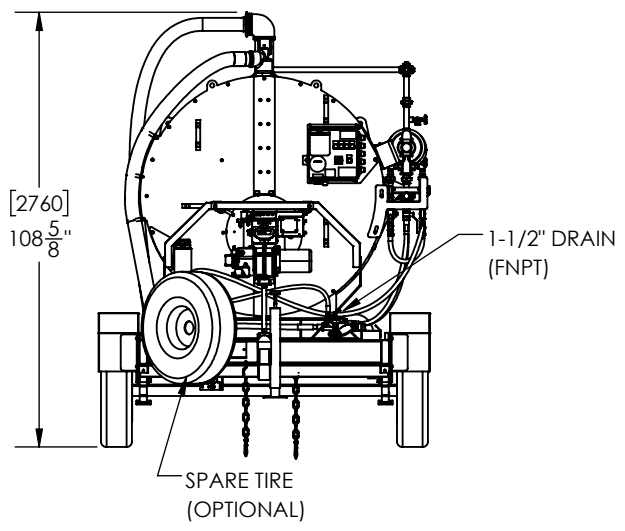
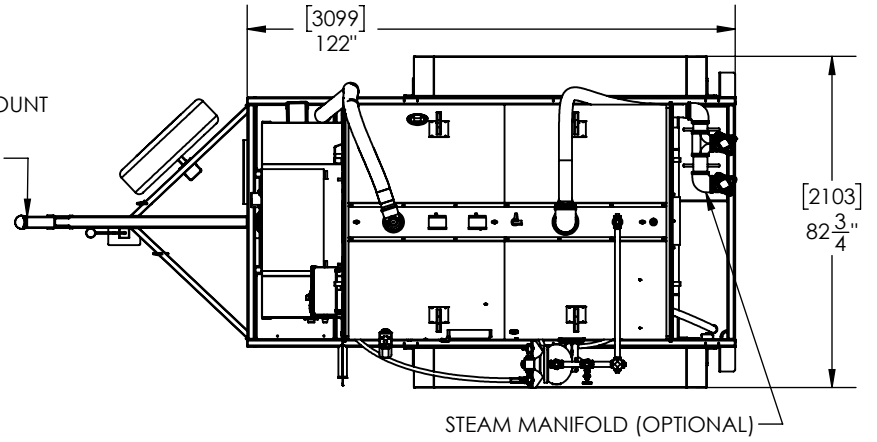

REV.	DESCRIPTION	DATE	BY	DO NOT SCALE DRAWING
A-07	UPDATED BURNER END PLATE	03/29/23	SB	PROPRIETARY AND CONFIDENTIAL THE INFORMATION CONTAINED IN THIS DRAWING IS THE SOLE PROPERTY OF SIOUX CORP. ANY REPRODUCTION IN PART OR AS A WHOLE WITHOUT WRITTEN PERMISSION OF SIOUX CORP IS PROHIBITED. DO NOT SCALE DRAWING
A-06	UPDATED NOTES/CALLOUTS	08/02/21	JS	
A-05	REMOVED KANBAN PART	07/21/21	LN	
A-04	ADDED FENDER ATTACHMENTS	07/19/21	LN	
A-01	ORIGINAL	6/19/2017	LN	

UNLESS NOTED:	DRN LN 6/19/17
DIMENSIONS IN INCHES. (mm) FOR REFERENCE ONLY.	CHK MW 6/19/17
TOLERANCES	GC
THIRD-ANGLE PROJECTION	SIZE A
LINEAR: ±1/2"	SCALE 1:48
ANGULAR: ±2°	FILE

SIOUX CORPORATION
 ONE SIOUX PLAZA, BERESFORD, SD 57004
 SF50D-TM
 GA22089 TRAILER SF-50
GA22089
 REV A-07 SH 1/1

DWG. NO. GA22089 REV. A-07 SHEET 1/1