

MODEL	APPROX. WEIGHT	
	LB	KG
SF25G-TM (DRY)	2750	1250
SF25G-TM (WET)	3900	1800

- WHEELS: STEEL 15" X 6"
- 6 BOLT 5.5" B.C.
- TIRES: 225-75-15 C-RATED
- AXLE: SINGLE 5200#
- SPRINGS: SLIPPER LEAF SPRINGS
- BRAKES: ELECTRIC DRUM
- PLUG: 7-WAY FLAT BLADE
- GVWR: 5200 LBS

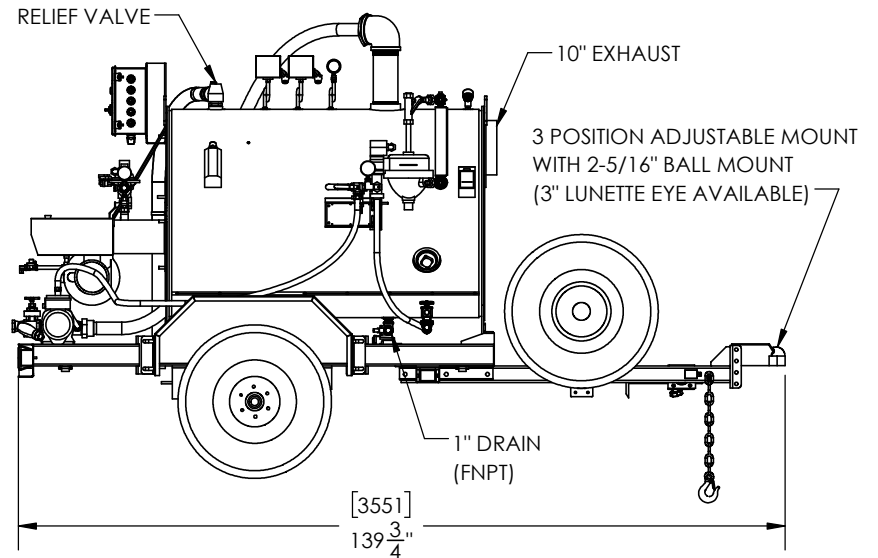
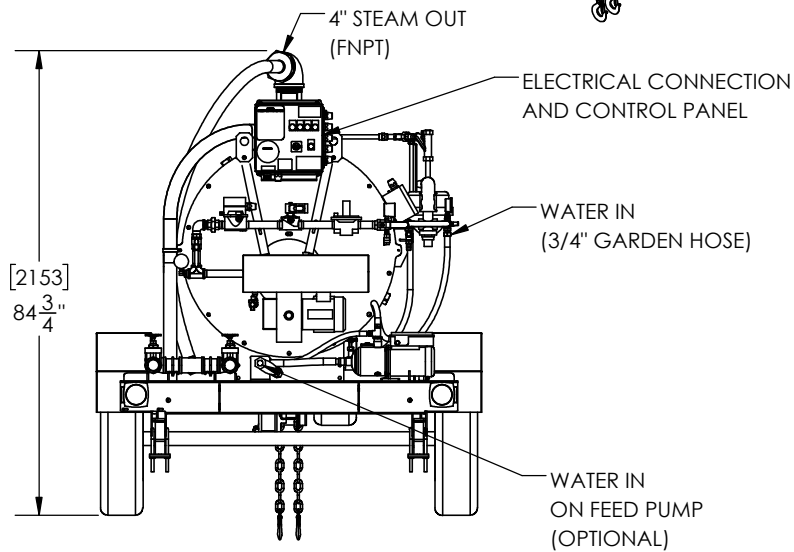
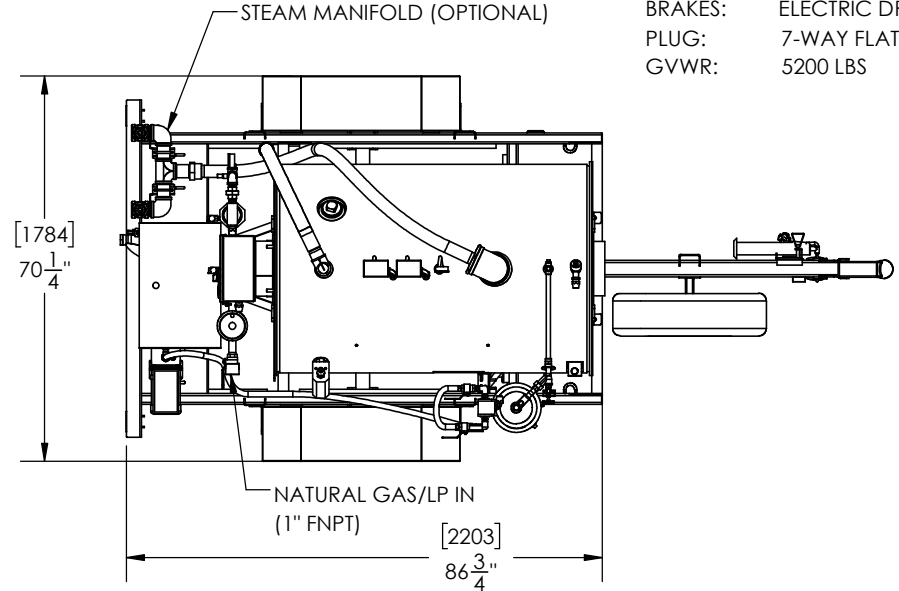
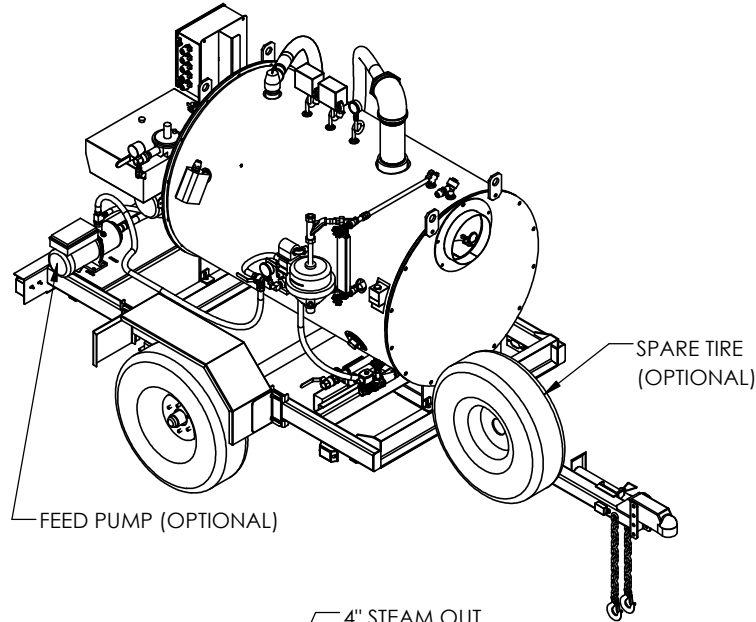

REV.	DESCRIPTION	DATE	BY
A-04	MOVED ENCLOSURE LOCATION	06/06/23	SB
A-03	UPDATED TRAILER NOTES	07/28/21	JS
A-02	UPDATED NOTES/CALLOUTS	05/19/21	JS
A-01	ORIGINAL	12/15/20	MW

PROPRIETARY AND CONFIDENTIAL
 THE INFORMATION CONTAINED IN THIS DRAWING IS THE SOLE PROPERTY OF SIOUX CORP. ANY REPRODUCTION IN PART OR AS A WHOLE WITHOUT WRITTEN PERMISSION OF SIOUX CORP IS PROHIBITED.

DO NOT SCALE DRAWING

UNLESS NOTED:	DRN	JZ11/23/2020
DIMENSIONS IN INCHES. (mm) FOR REFERENCE ONLY.	CHK	MW 12/15/20
TOLERANCES	SIZE	A SCALE 1:35
LINEAR: ±1/2"	THIRD-ANGLE PROJECTION	
ANGULAR: ±2°		

SIOUX
 SIOUX CORPORATION, ONE SIOUX PLAZA, BERESFORD, SD 57004

SF25-TM

GA23662

REV A-04 SH 1/1

DWG. NO. GA23662
 REV. A-04
 SHEET 1/1