

APPLICABLE MACHINES		
MODEL	APPROX. DRY WEIGHT	
	LB	KG
H5.5D3000-D	985	447

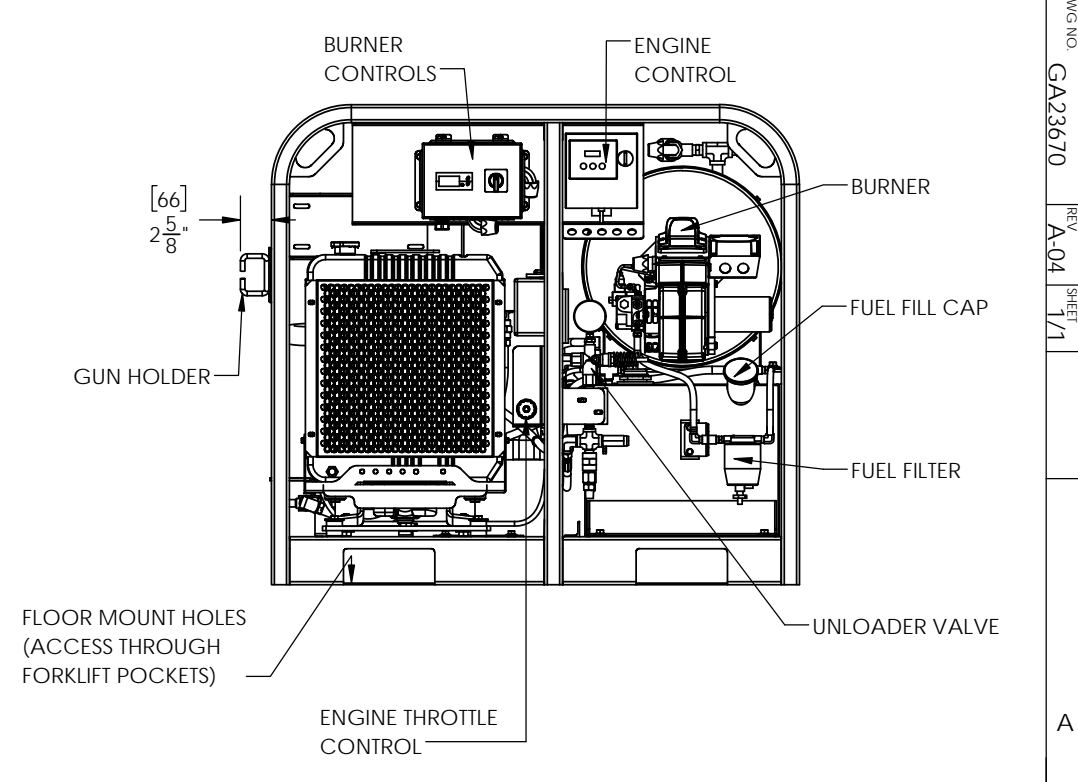
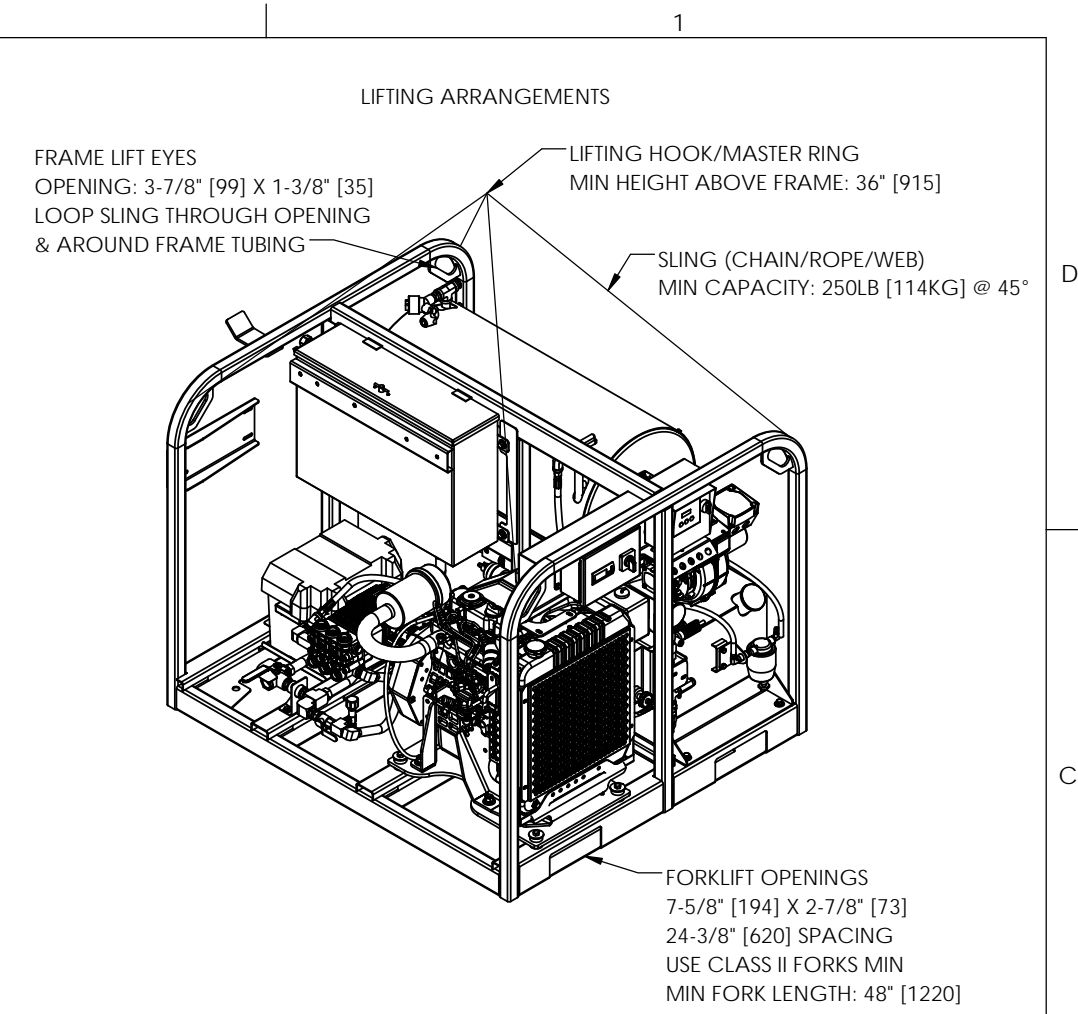
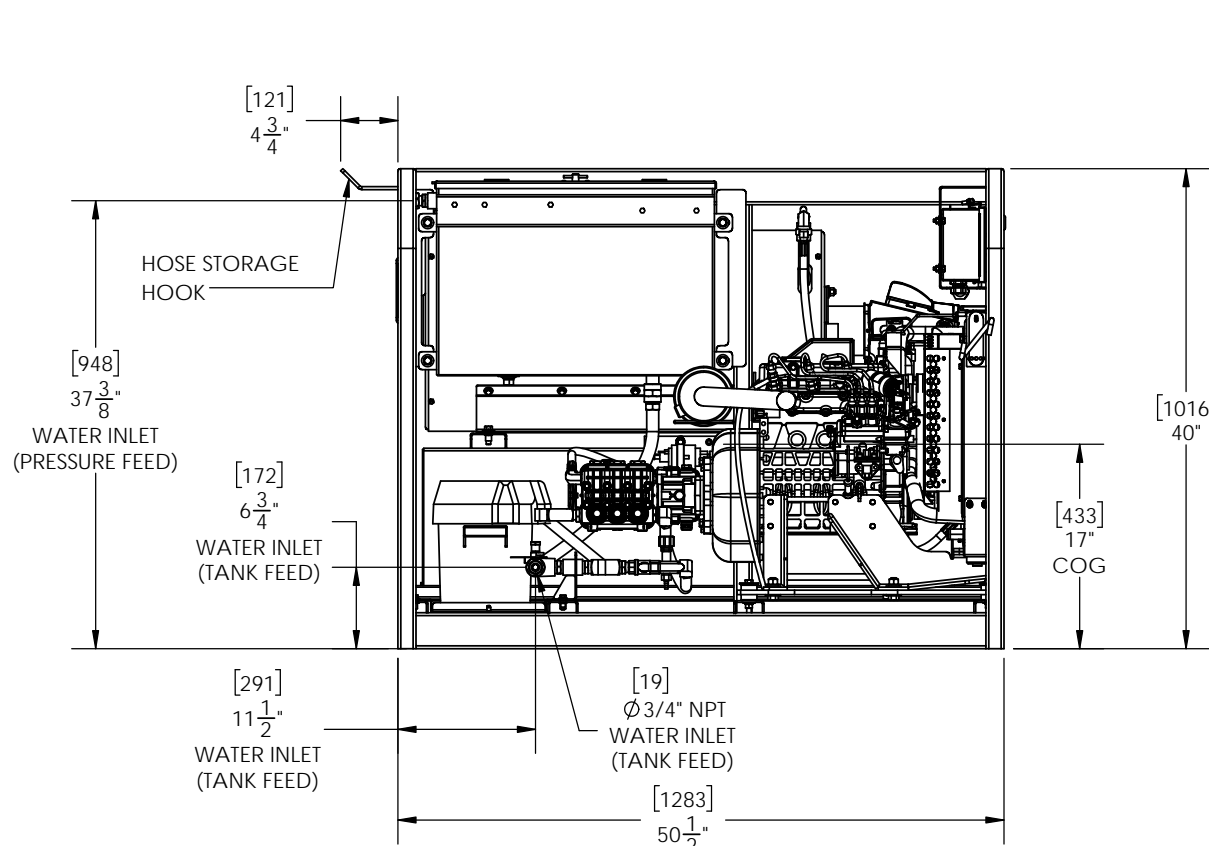
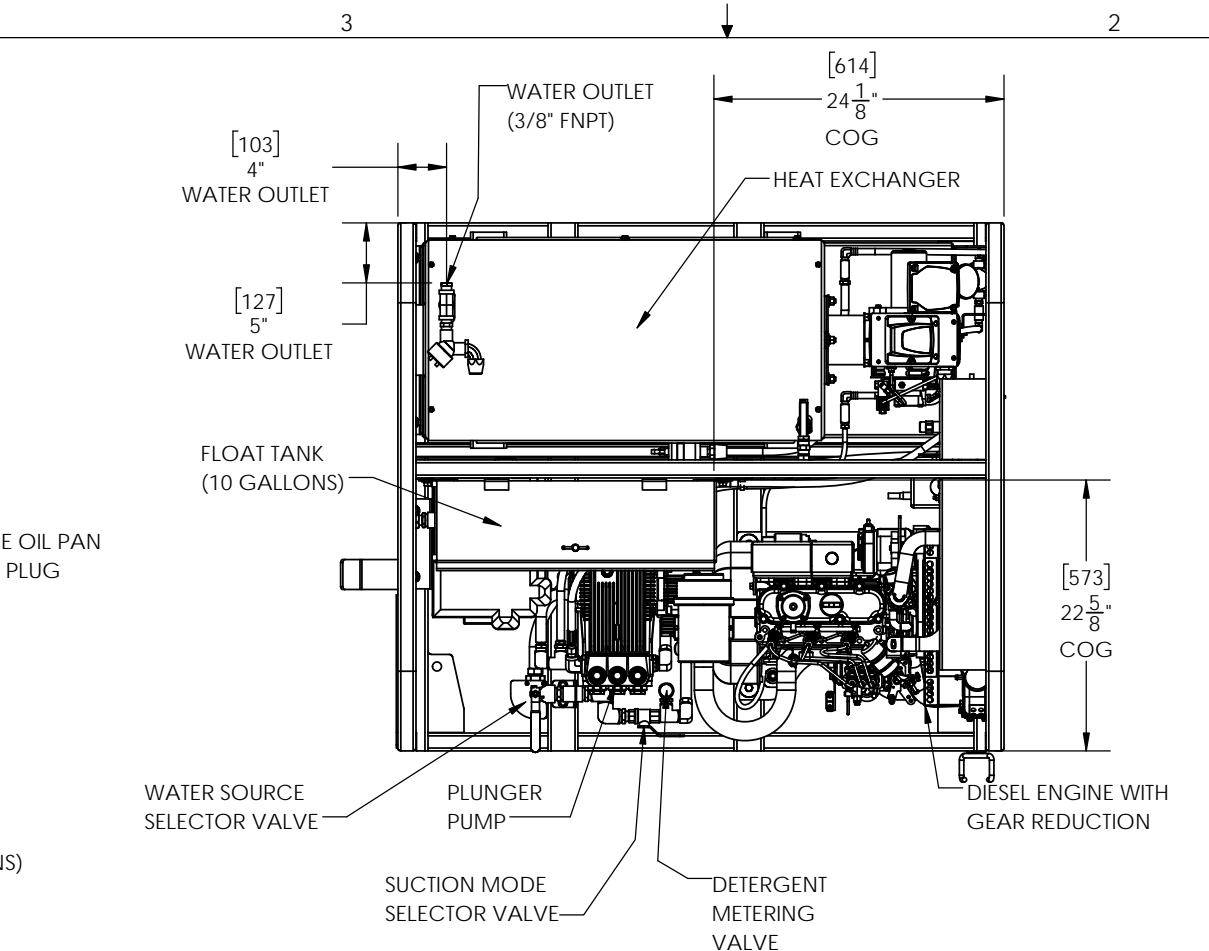
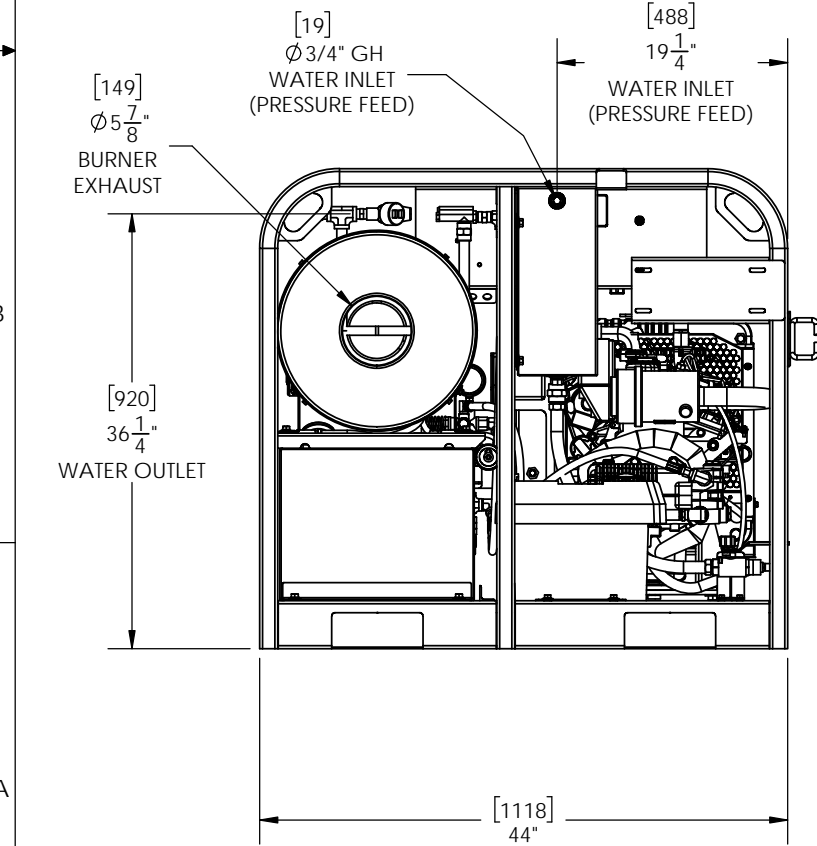
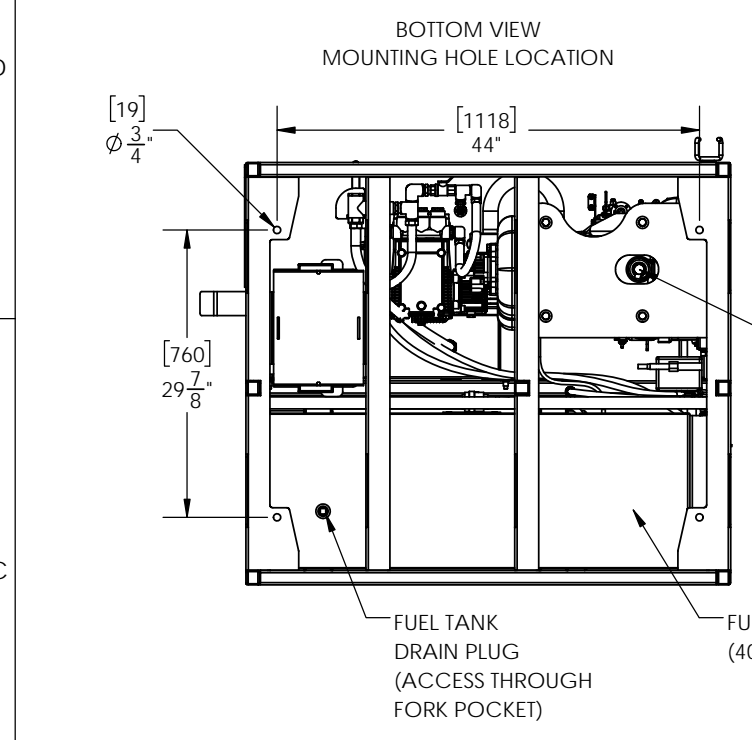

REV.	DESCRIPTION	DATE	BY
A-04	ADDED GUN HOLDER	05/13/21	JZ
A-03	POST-PROTOTYPE RELEASE	05/04/21	JL
A-02	PRODUCTION RELEASE	01/13/21	JL
A-01	ORIGINAL	01/13/21	LN

PROPRIETARY COPYRIGHT AND CONFIDENTIAL
 Copyright © 5/13/2021 SIOUX CORPORATION.
 The information contained in this drawing is the sole property of Sioux Corp. This information is subject to recall at any time and is not to be used in any way detrimental to Sioux's interests. Any reproduction in part or as a whole without written permission of Sioux Corp is prohibited. Use of material is subject to the terms of website use listed at www.siuox.com

UNLESS NOTED:	DRN LN 10/20/2020
DIMENSIONS [mm] IN	CHK LN 1/13/2021
TOLERANCES	QC
LINEAR: ±[13] 1/2	THIRD-ANGLE PROJECTION
ANGULAR: ±2°	SIZE B

SIOUX CORPORATION
 ONE SIOUX PLAZA, BERESFORD, SD 57004

GENERAL ARRANGEMENT H5.5D3000-D

GA23670

REV A-04 SH 1/1

DWG NO: GA23670 REV: A-04 SHEET: 1/1