

MODEL	APPROX. WEIGHT	
	LB	KG
SF20D-TM (DRY)	3150	1450
SF20D-TM (WET)	4750	2150

WHEELS: STEEL 15" X 6"
 6 BOLT 5.5" B.C.
 TIRES: 225-75-15 C-RATED
 AXLE: SINGLE 5200#
 SPIRNGS: SLIPPER LEAF SPRINGS
 BRAKES: ELECTRIC DRUM
 PLUG: 7-WAY FLAT BLADE
 GVWR: 5200 LBS

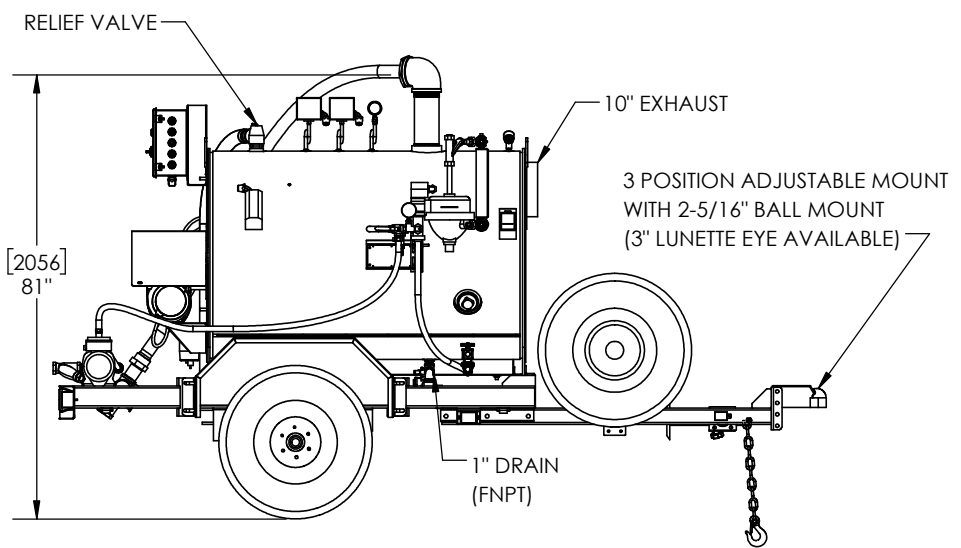
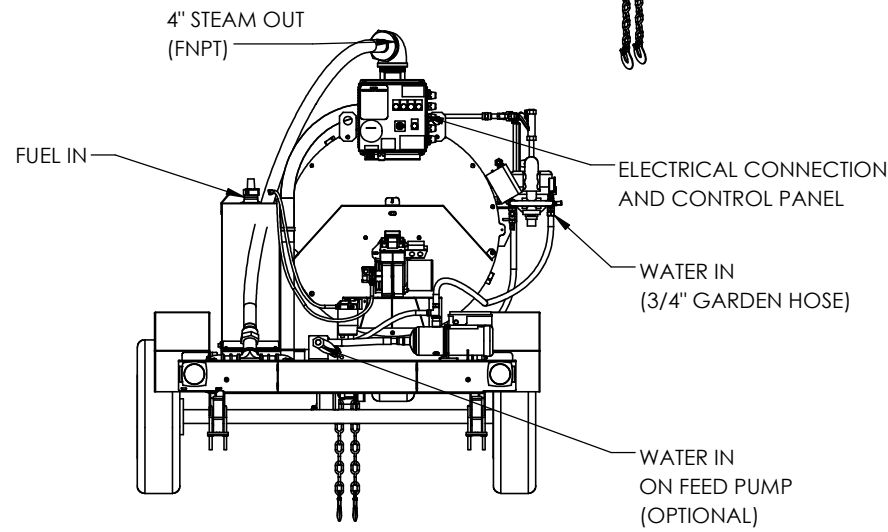
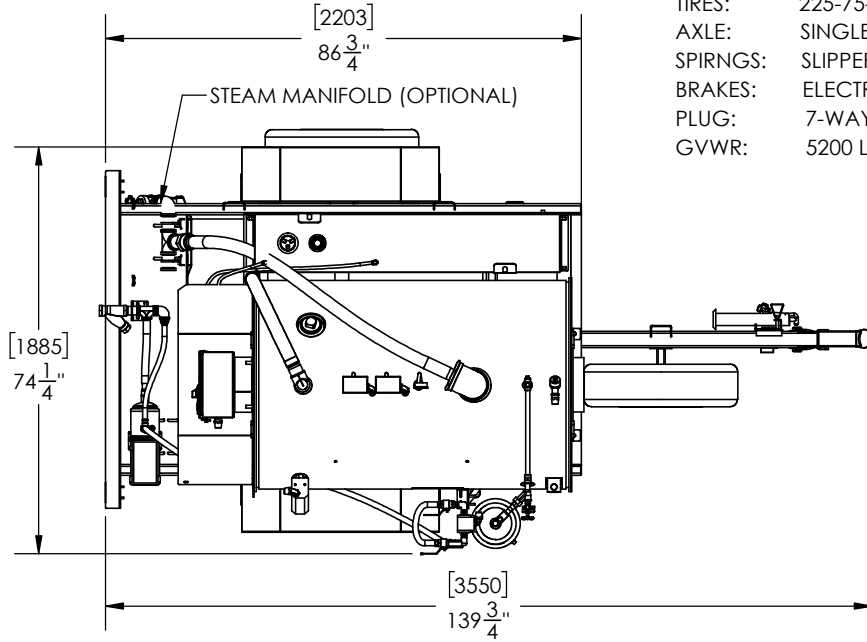
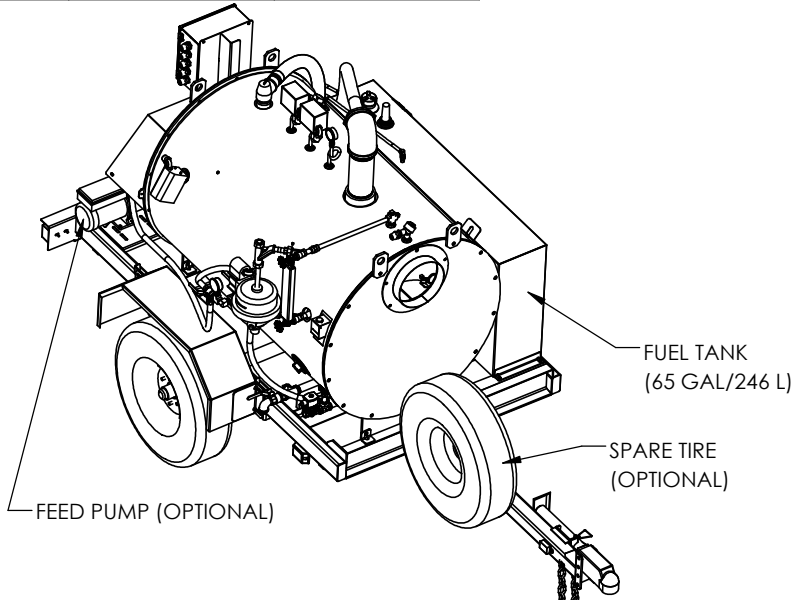

REV.	DESCRIPTION	DATE	BY	DO NOT SCALE DRAWING
A-08	UPDATED TRAILER NOTES	06/06/23	SB	PROPRIETARY AND CONFIDENTIAL THE INFORMATION CONTAINED IN THIS DRAWING IS THE SOLE PROPERTY OF SIOUX CORP. ANY REPRODUCTION IN PART OR AS A WHOLE WITHOUT WRITTEN PERMISSION OF SIOUX CORP IS PROHIBITED.
A-07	MOVED ENCLOSURE LOCATION	03/13/23	SB	
A-06	UPDATED TRAILER NOTES	07/28/21	JS	
A-05	EDITED/ADDED CALLOUTS	05/26/21	JS	
A-01	ORIGINAL	12/15/20	MW	

UNLESS NOTED:	DRN	JZ11/23/2020
DIMENSIONS IN INCHES. [mm] FOR REFERENCE ONLY.	CHK	MW 12/15/20
TOLERANCES	SIZE	A SCALE 1:35
LINEAR: ±1/2"	THIRD-ANGLE PROJECTION	
ANGULAR: ±2°		

SIOUX
SIOUX CORPORATION, ONE SIOUX PLAZA, BERESFORD, SD 57004

SF20D-TM

GA23735

REV **A-08** SH 1/1

DWG. NO. GA23735
 REV. A-08
 SHEET 1/1