

APPLICABLE MACHINES		
MODEL	APPROX. WEIGHT	
	LB	KG
H5.5D3000-G	840	381

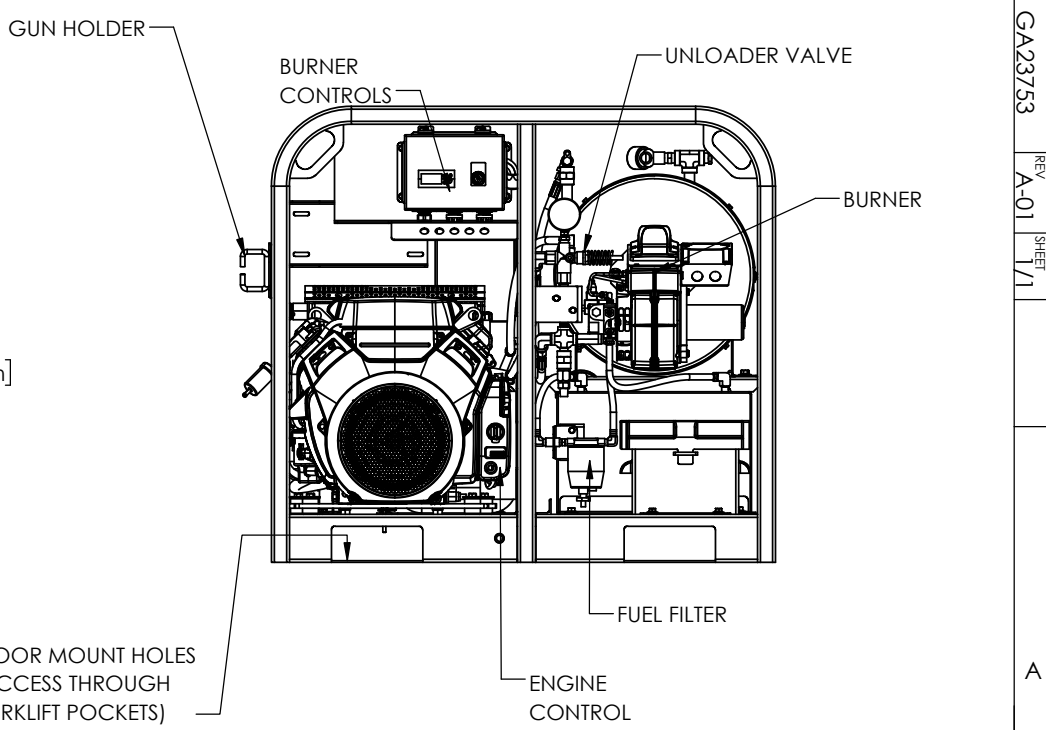
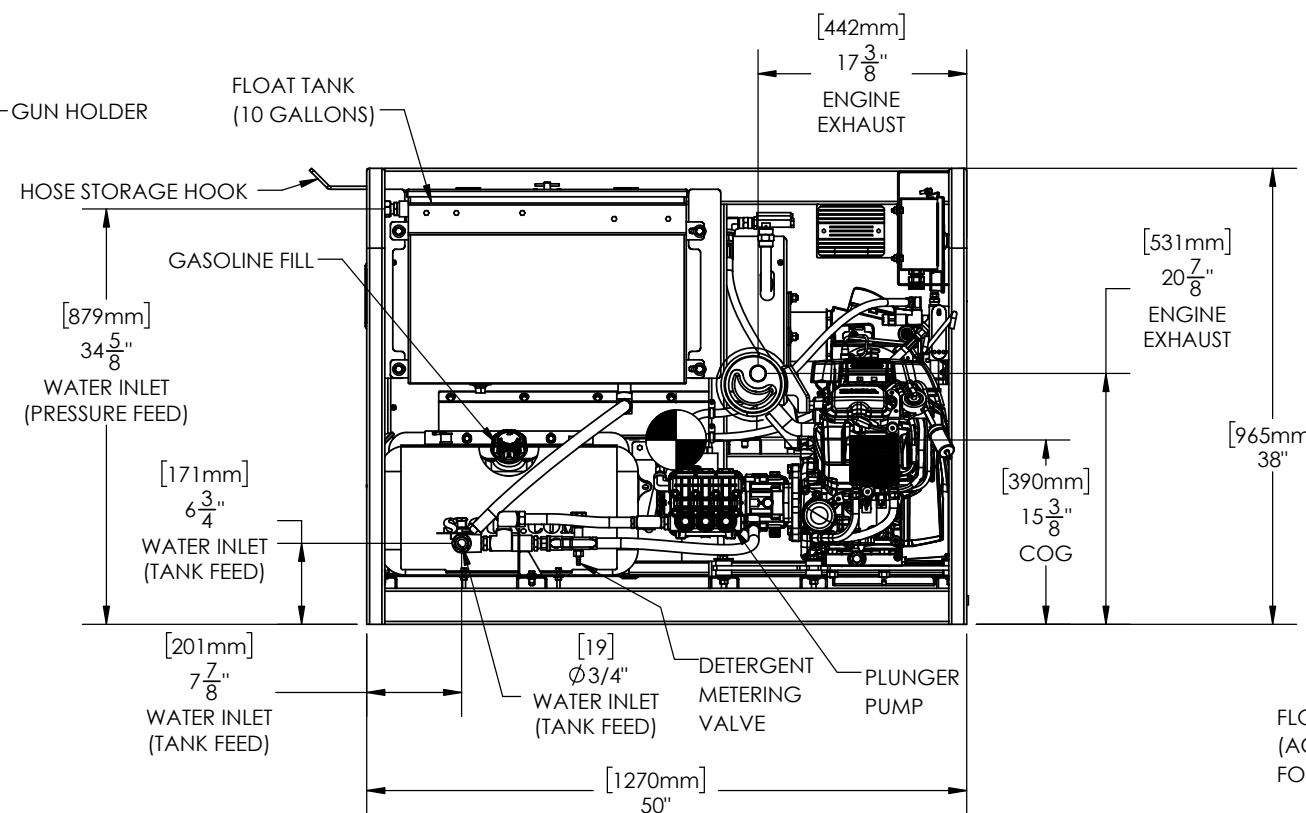
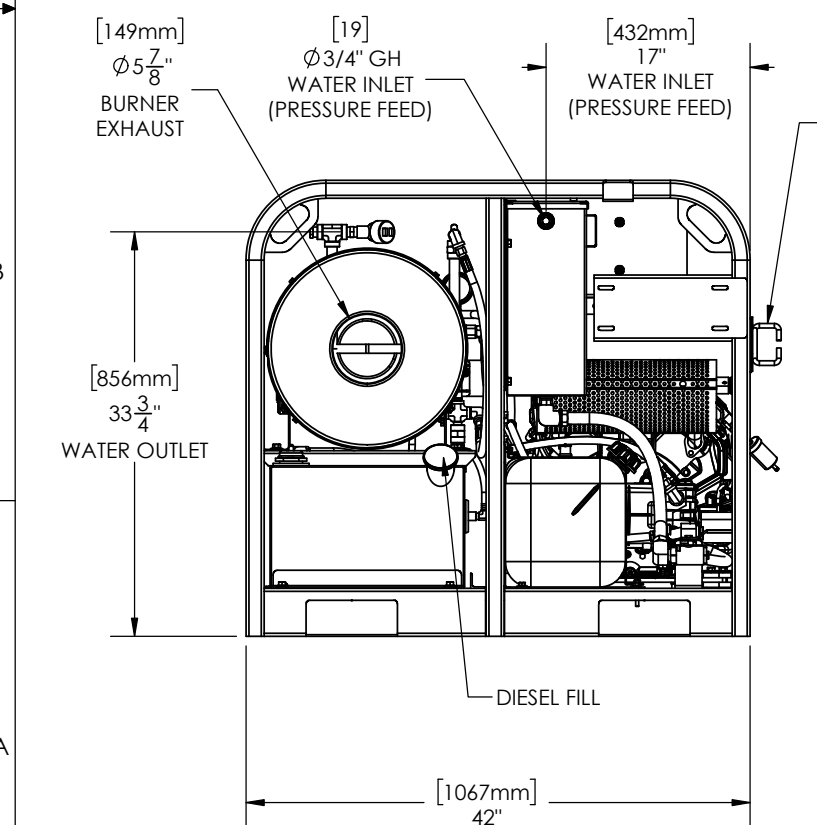
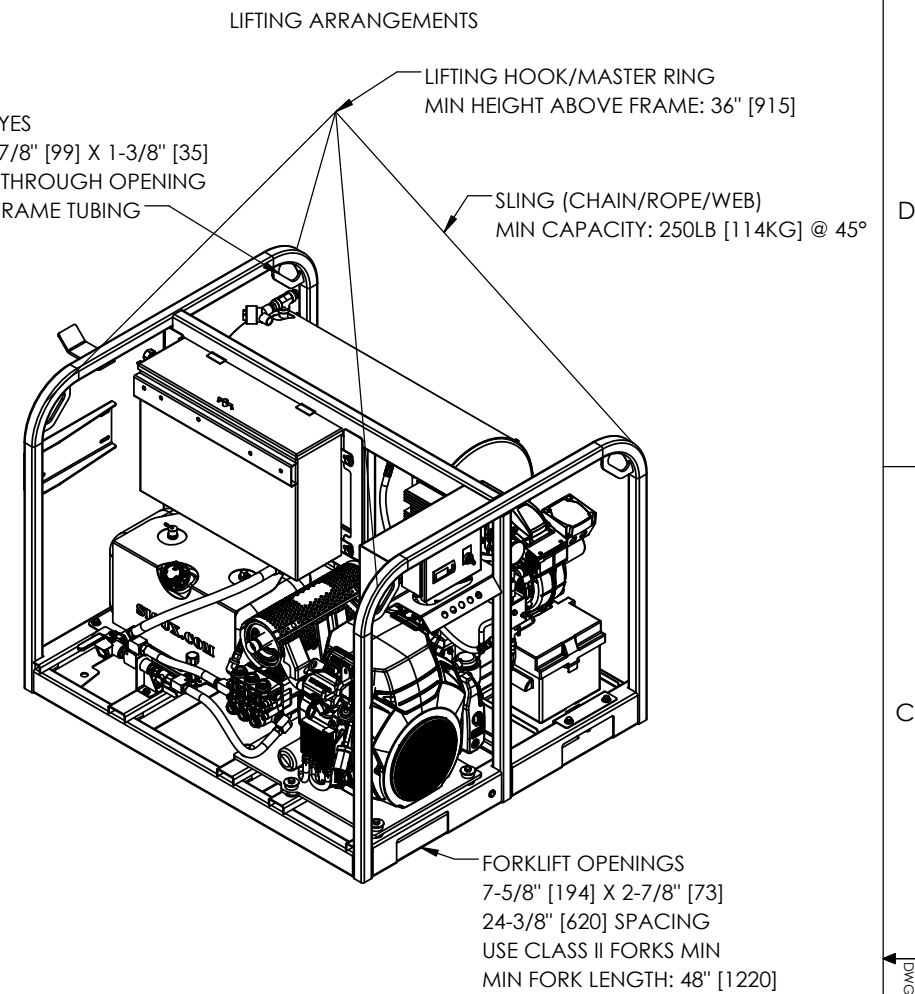
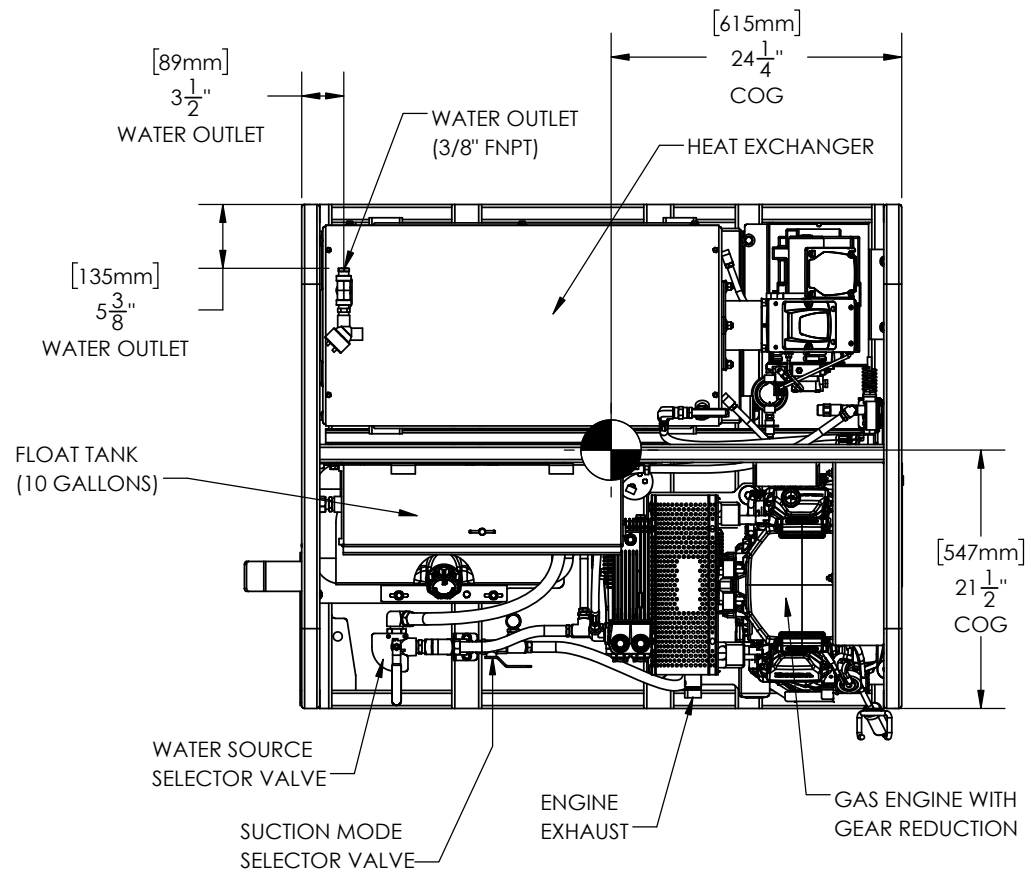
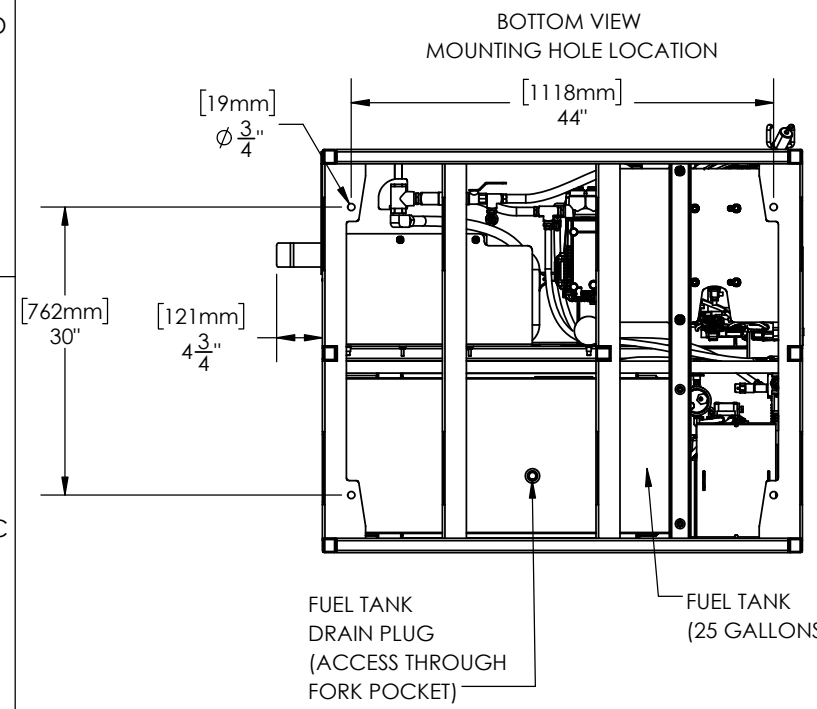

REV.	DESCRIPTION	DATE	BY
A-01	ORIGINAL	05/24/21	LN

PROPRIETARY COPYRIGHT AND CONFIDENTIAL
Copyright © 5/24/2021 SIOUX CORPORATION. The information contained in this drawing is the sole property of Sioux Corp. This information is subject to recall at any time and is not to be used in any way detrimental to Sioux's interests. Any reproduction in part or as a whole without written permission of Sioux Corp is prohibited. Use of material is subject to the terms of website use listed at www.siuox.com

UNLESS NOTED:	DRN JL 1/13/2021	SIOUX CORPORATION ONE SIOUX PLAZA, BERESFORD, SD 57004
DIMENSIONS [mm] IN	CHK LN 5/24/2021	
TOLERANCES	QC	GENERAL ARRANGEMENT - H5.5D3000-G
LINEAR: $\pm 1/32$	THIRD-ANGLE PROJECTION	GA23753-ENGINE DRIVE
ANGULAR: $\pm 2^\circ$	SIZE B	SCALE 1:24
		FILE

GA23753 REV A-01 SH 1/1