

MODEL	APPROX. WEIGHT	
	LB	KG
H3.5D3000-G	560	254

BOTTOM VIEW

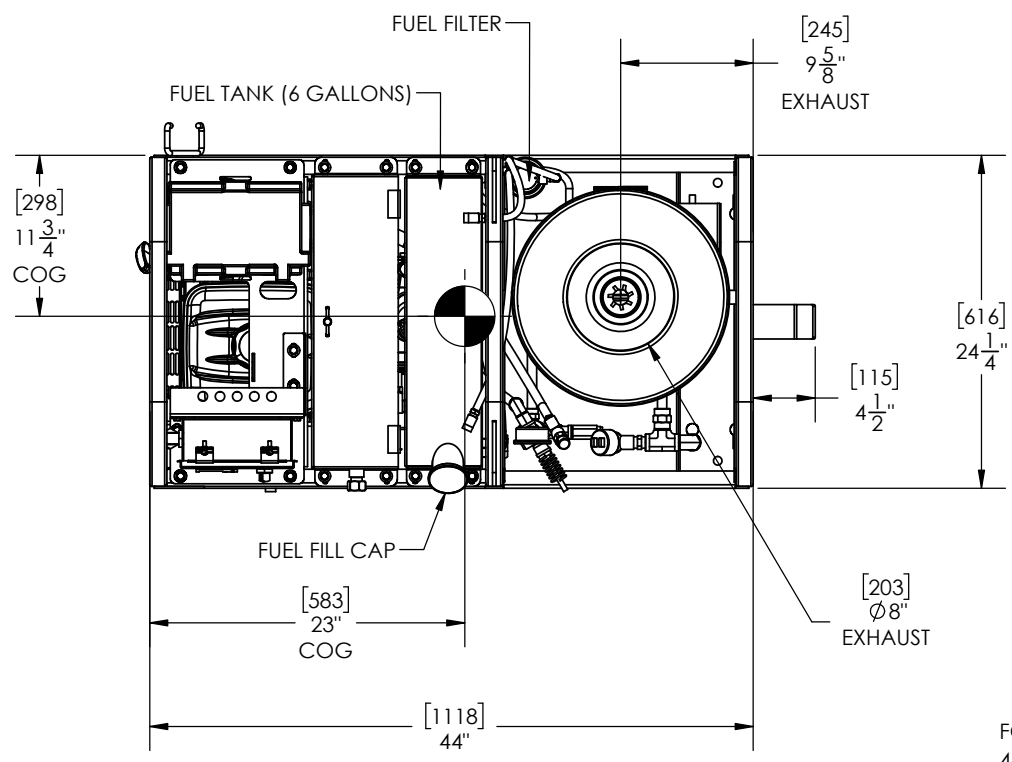

LIFTING ARRANGEMENTS

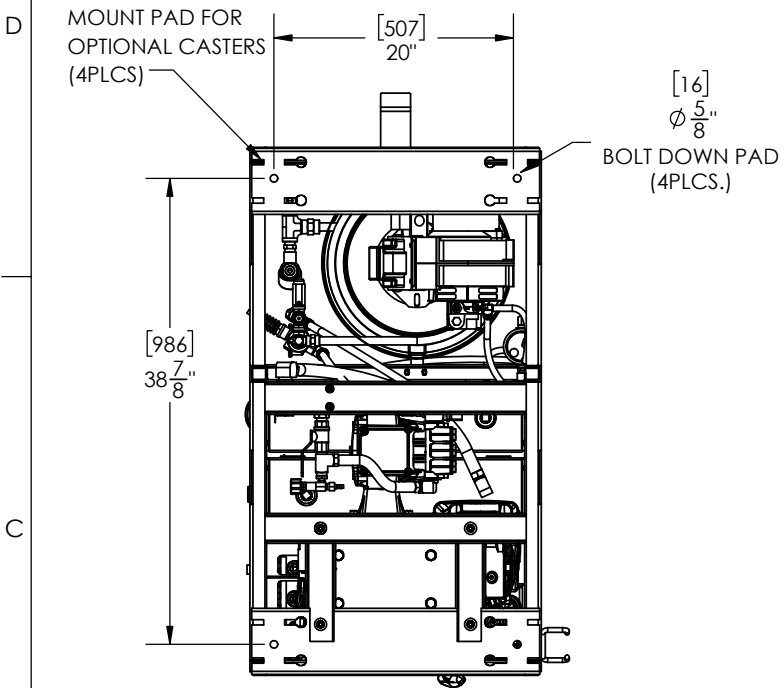
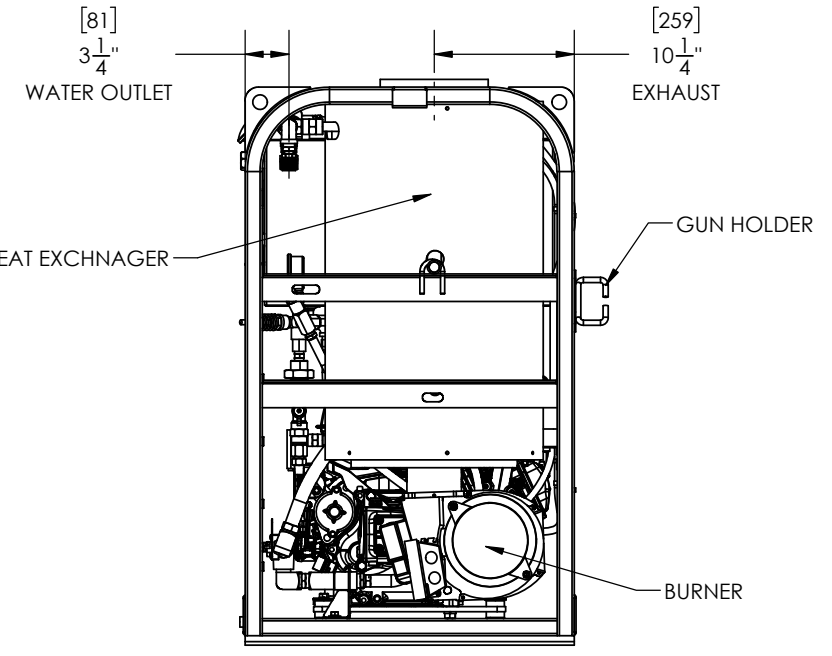
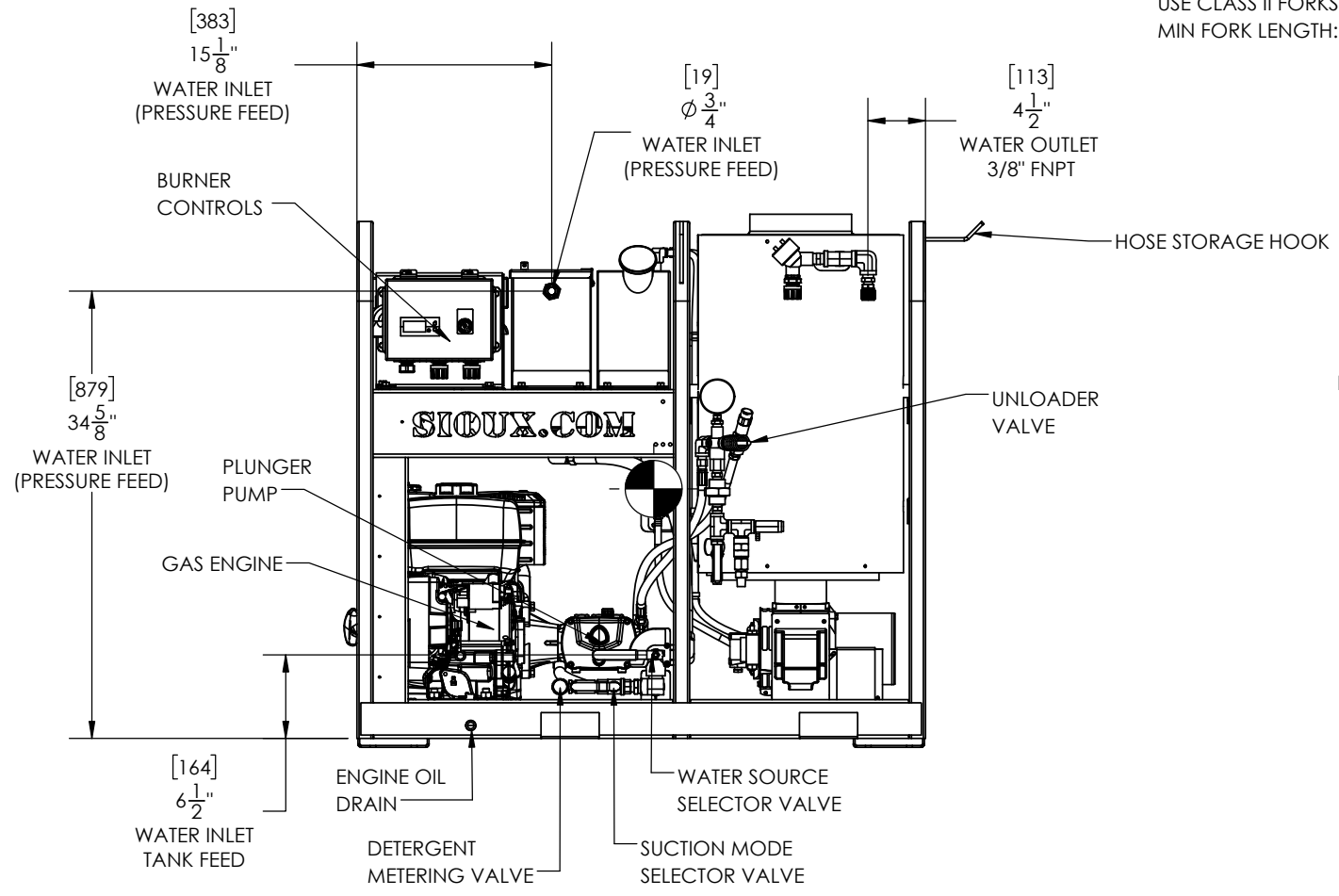
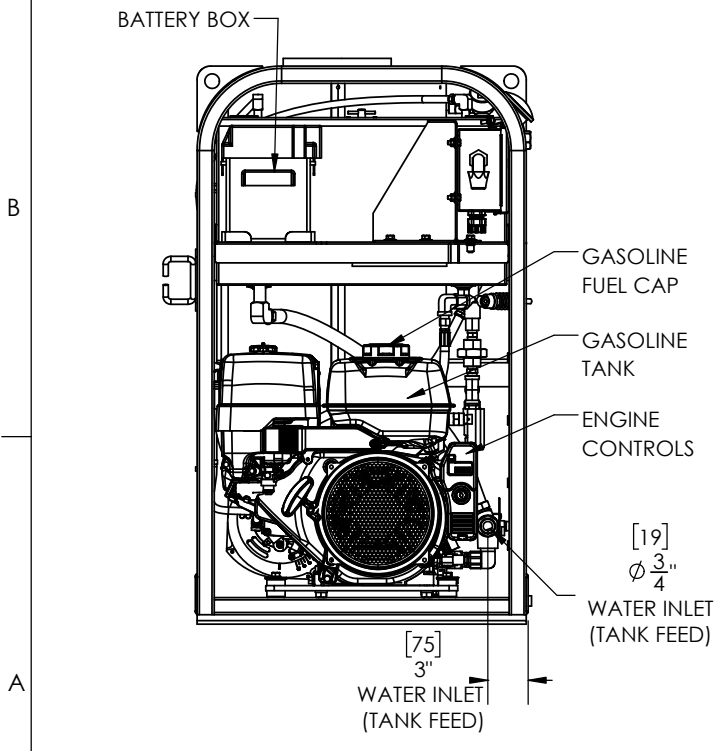
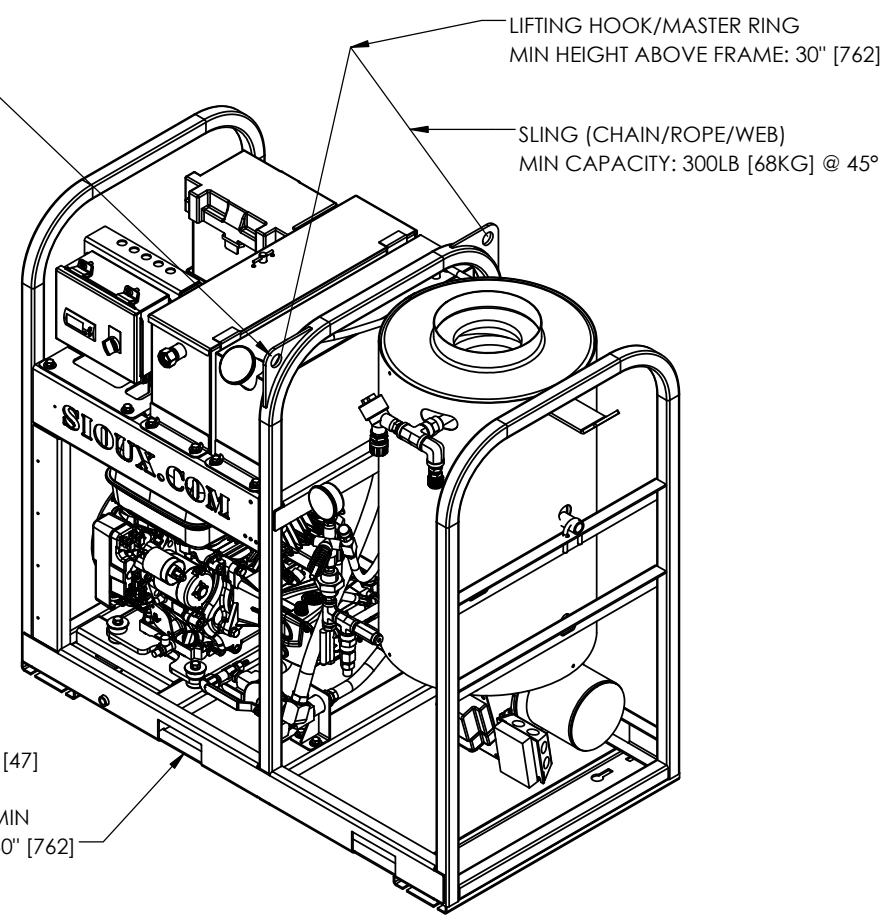

REV.	DESCRIPTION	DATE	BY
A-06	UPDATED CASTER NOTE - OPTIONAL	03/13/24	MW
A-05	UPDATED LIFT POINTS	04/20/23	JZ
A-04	OVERALL DIMENSIONING	05/13/21	JZ
A-03	ADDED GUN HOLDER	05/13/21	JZ
A-02	POST-PROTOTYPE RELEASE	05/11/21	JL

**PROPRIETARY COPYRIGHT AND CONFIDENTIAL**  
Copyright © 03/13/24 SIOUX CORPORATION.  
The information contained in this drawing is the sole property of Sioux Corp. This information is subject to recall at any time and is not to be used in any way detrimental to Sioux's interests. Any reproduction in part or as a whole without written permission of Sioux Corp is prohibited. Use of material is subject to the terms of website use listed at www.siuox.com

UNLESS NOTED:	DRN LN	1/25/2021
DIMENSIONS [mm] IN	CHK JL	01/27/21
TOLERANCES	QC	
LINEAR: $\pm [13] 1/2$	THIRD-ANGLE PROJECTION	SIZE B
ANGULAR: $\pm 2^\circ$		SCALE 1:24

<b>SIOUX CORPORATION</b>	
ONE SIOUX PLAZA, BERESFORD, SD 57004	
H3.5D3000-G Assembly	
GA23885	GA23885
REV A-06	SH 1/1

DWG NO. GA23885 REV A-06 SHEET 1/1