

4

3

2

1

APPLICABLE MACHINES

MODEL	APPROX. WEIGHT	
	LB	KG
H5.5D3000-DTTM (DRY)	2550	1160
H5.5D3000-DTTM (WET)	7840	3560

WHEELS: STEEL 15" X 6"
6 BOLT 5.5" B.C.

TIRES: 225-75-15 C-RATED

AXLES: TANDEM 5200#

SPRINGS: SLIPPER LEAF SPRINGS

BRAKES: ELECTRIC BRAKES

PLUG: 7-WAY PLUG

GVWR: 10,400 LBS

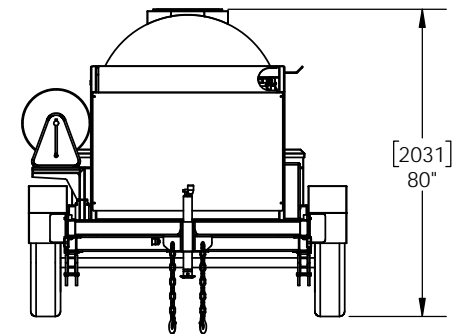
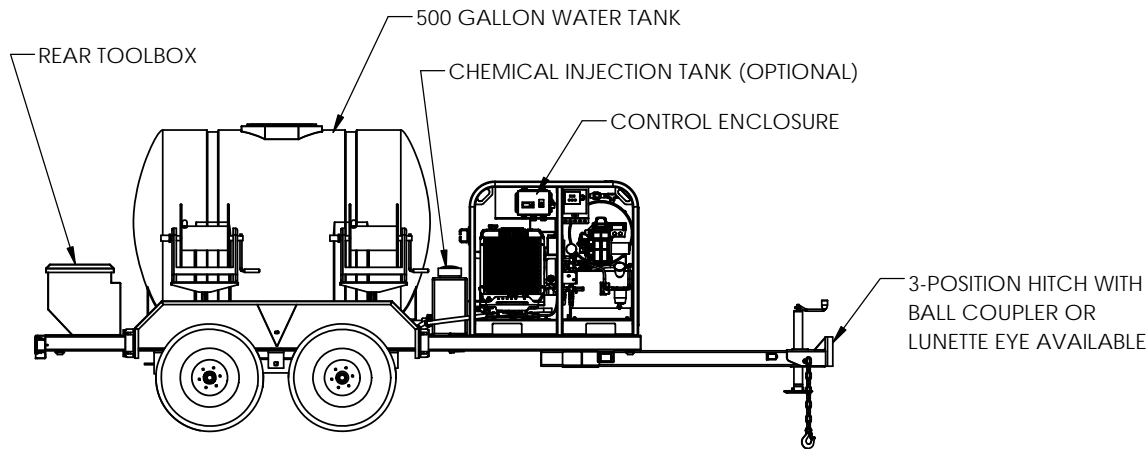
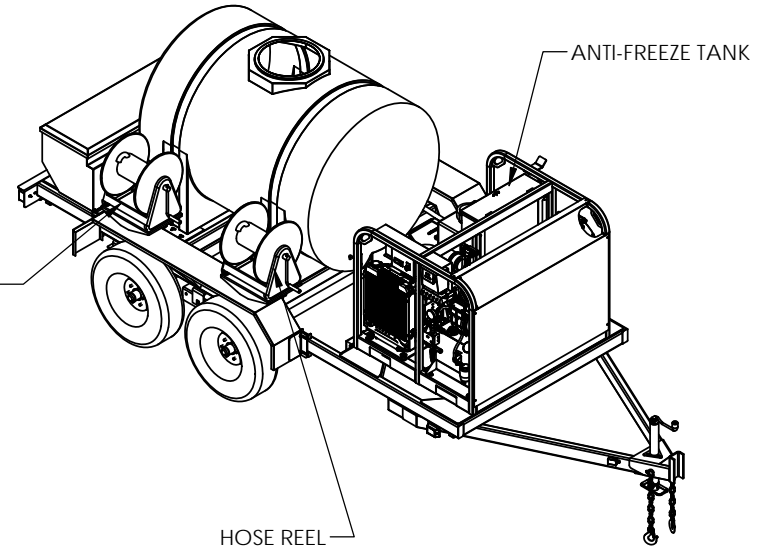
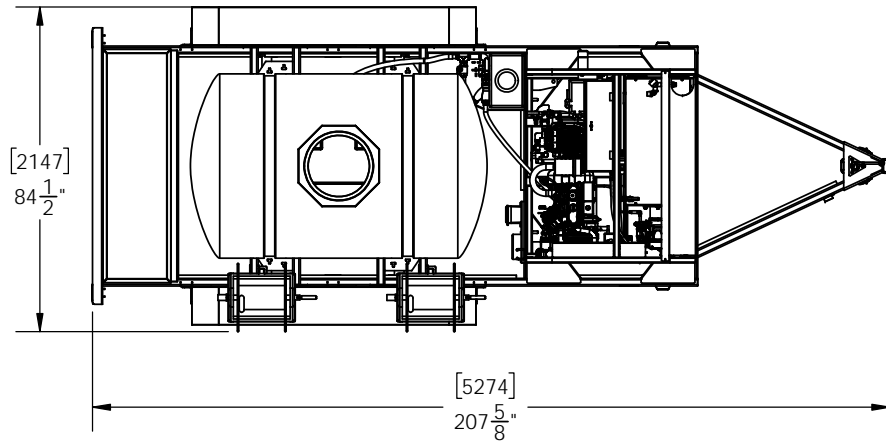

PROPRIETARY COPYRIGHT AND CONFIDENTIAL
Copyright © 11/16/2021 SIOUX CORPORATION.
The information contained in this drawing is the sole property of Sioux Corp. This information is subject to recall at any time and is not to be used in any way detrimental to Sioux's interests.
Any reproduction in part or as a whole without written permission of Sioux Corp is prohibited.
Use of material is subject to the terms of website use listed at www.siuox.com

UNLESS NOTED:
DIMENSIONS
[mm] IN
TOLERANCES
LINEAR: $\pm[13] 1/2$
ANGULAR: $\pm 2^\circ$

DRN JZ 4/1/2021
CHK MW11/16/2021
QC
THIRD-ANGLE PROJECTION
SIZE A SCALE 1:50 FILE

SIOUX CORPORATION
ONE SIOUX PLAZA, BERESFORD, SD 57004

H5.5D3000-D HIGHWAY TRAILER GA

GA24017

REV A-01

SH 1/1

REV.	DESCRIPTION	DATE	BY
A-01	ORIGINAL	11/16/21	MW

4

3

1

DWG NO GA24017 REV A-01 SHEET 1/1