

MODEL	APPROX. WEIGHT	
	LB	KG
SF20 LEG MOUNTED (DRY)	1850	850
SF20 LEG MOUNTED (WET)	3000	1400

NOTE: SUGGESTED MINIMUM CLEARANCES FOR SERVICE ACCESS ARE 48" (1200mm) FOR THE ENDS AND 24" (600mm) ALONG EACH SIDE

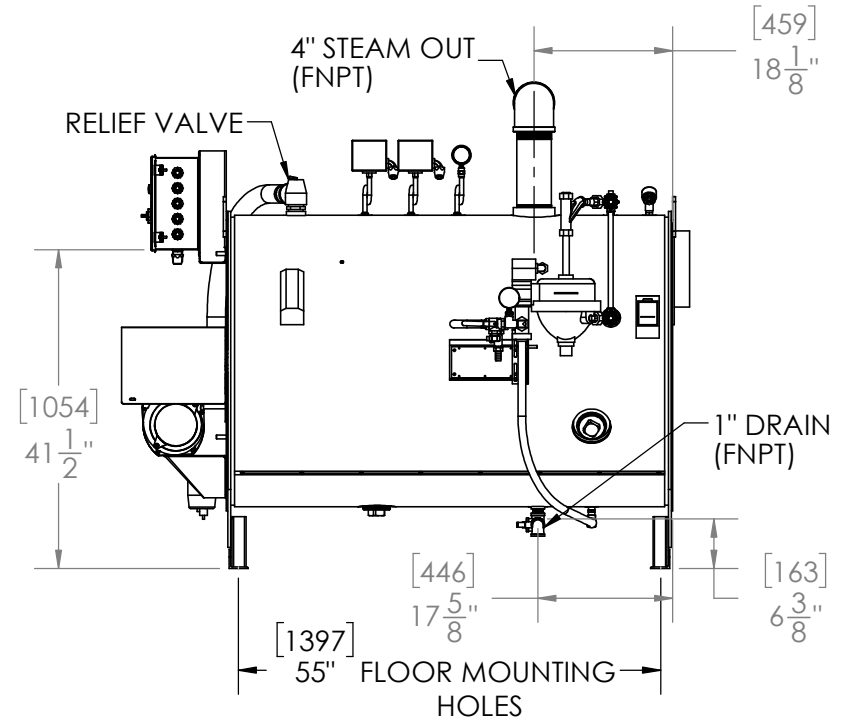
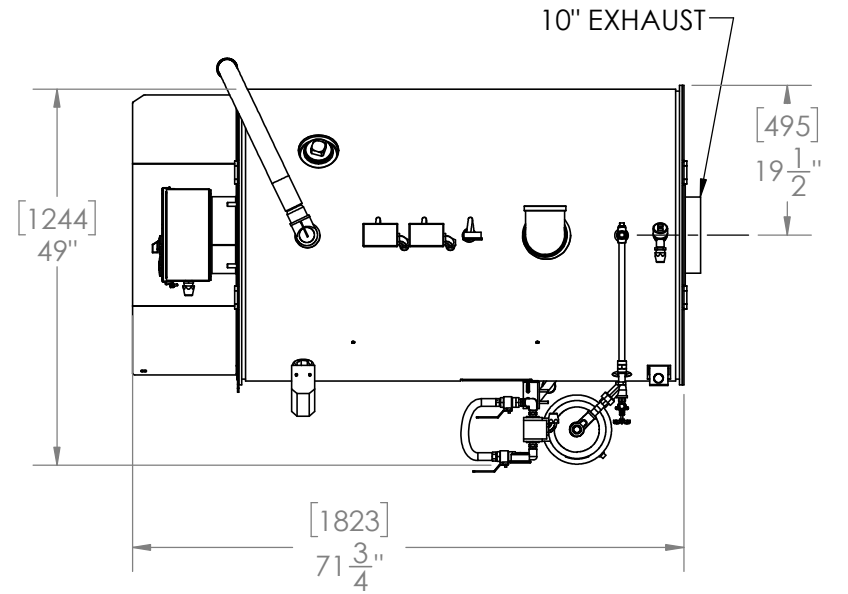
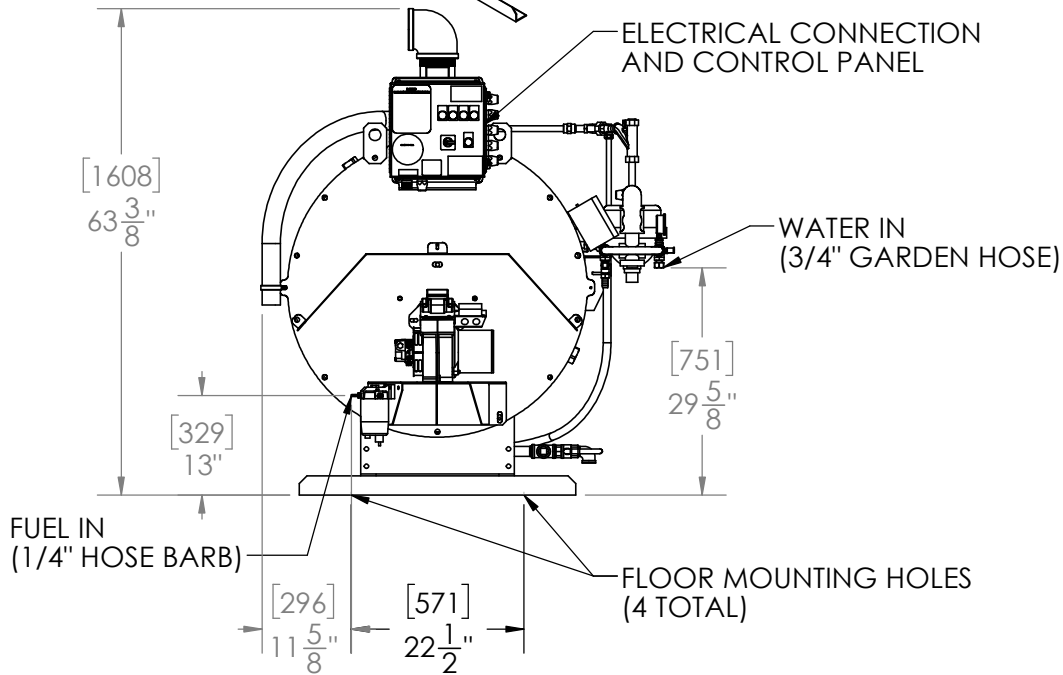
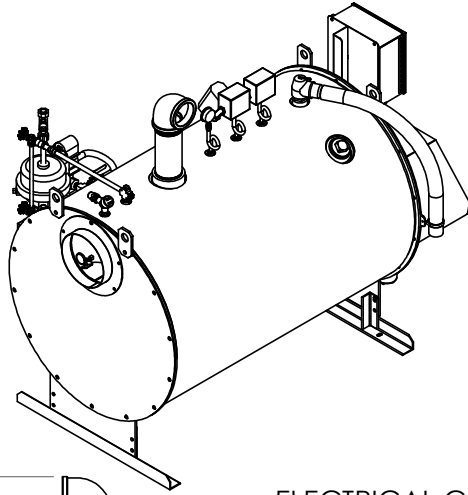

REV.	DESCRIPTION	DATE	BY
A-04	MOVED ENCLOSURE LOCATION	05/30/23	SB
A-03	UPDATED NOTES/CALLOUTS	08/03/21	JS
A-02	CHANGED VIEWS/ADDED NOTES	06/01/21	JS
A-01	ORIGINAL	05/26/21	JZ

PROPRIETARY AND CONFIDENTIAL
 THE INFORMATION CONTAINED
 IN THIS DRAWING IS THE SOLE
 PROPERTY OF SIOUX CORP.
 ANY REPRODUCTION IN PART OR
 AS A WHOLE WITHOUT WRITTEN
 PERMISSION OF SIOUX CORP
 IS PROHIBITED.

DO NOT SCALE DRAWING

UNLESS NOTED:
 DIMENSIONS IN
 INCHES. [mm] FOR
 REFERENCE ONLY.
 TOLERANCES
 LINEAR: ±1/2"
 ANGULAR: ±2°

DRN	JS	5/26/2021
CHK	JZ	05/26/21
SIZE	A	SCALE 1:25
THIRD-ANGLE PROJECTION		

SIOUX
 SIOUX CORPORATION, ONE SIOUX PLAZA, BERESFORD, SD 57004

SF-20 LEG MOUNTED

GA24068 REV **A-04** SH **1/1**