

MODEL	APPROX. WEIGHT	
	LB	KG
SF25 LEG MOUNTED (DRY)	1900	850
SF25 LEG MOUNTED (WET)	3050	1400

NOTE: SUGGESTED MINIMUM CLEARANCES FOR SERVICE ACCESS ARE 48" (1200mm) FOR THE ENDS AND 24" (600mm) ALONG EACH SIDE

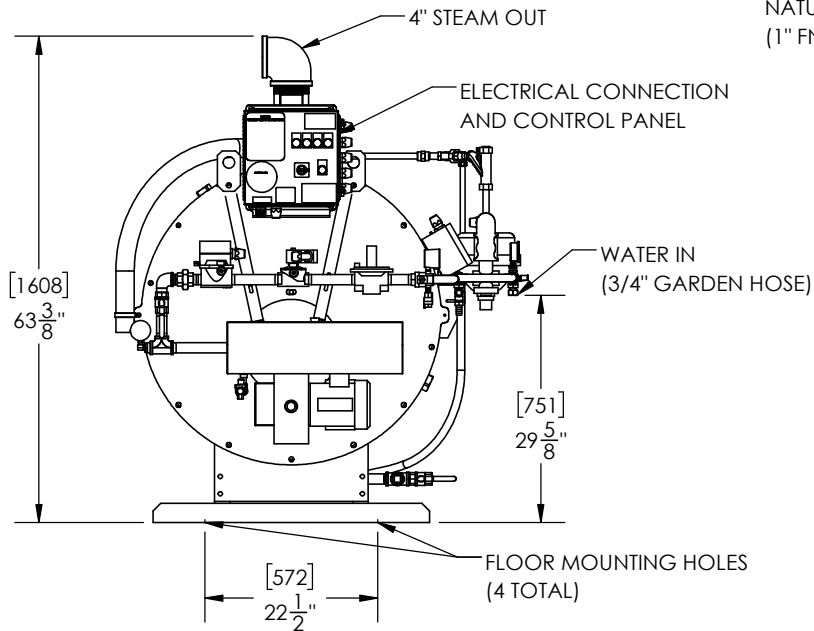

NATURAL GAS/LP IN (1" FNPT)

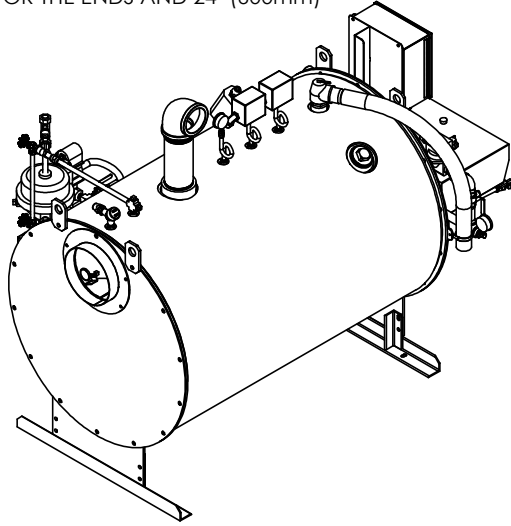
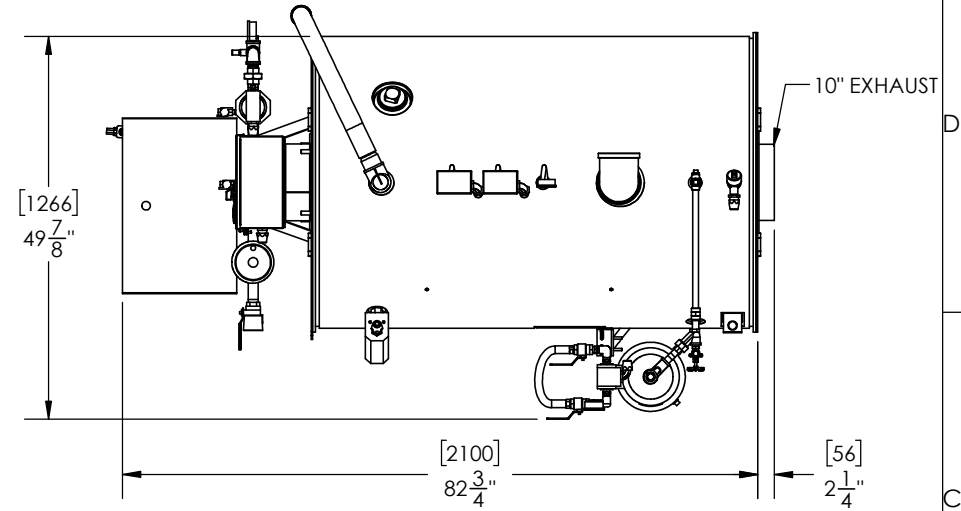
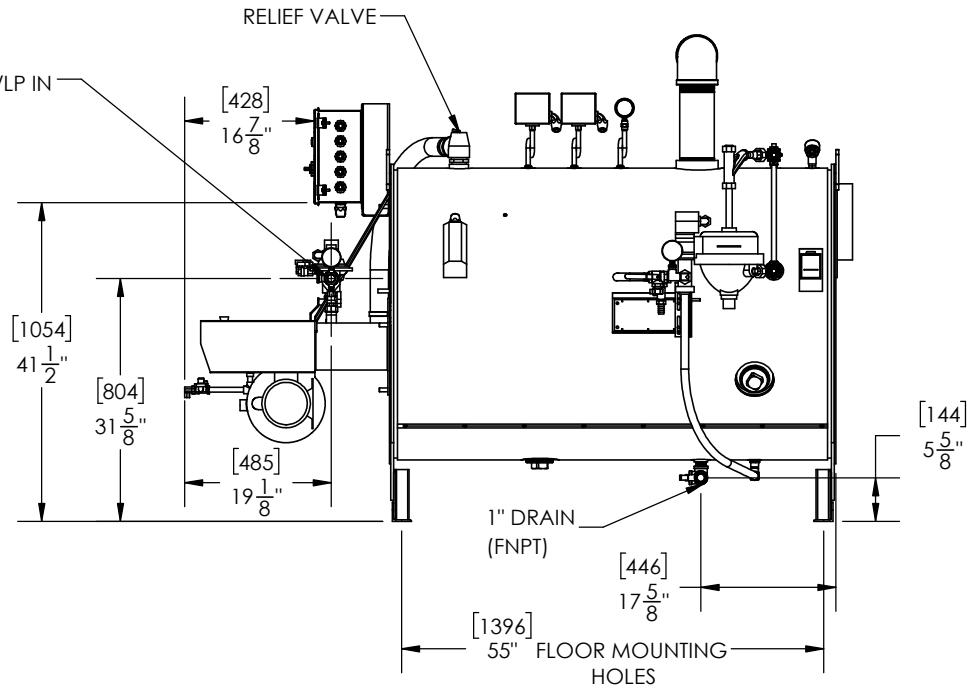

REV.	DESCRIPTION	DATE	BY
A-04	MOVED ENCLOSURE LOCATION	06/06/23	SB
A-03	UPDATED NOTES/CALLOUTS	07/28/21	JS
A-01	ORIGINAL	05/26/21	JZ

**PROPRIETARY AND CONFIDENTIAL**  
 THE INFORMATION CONTAINED IN THIS DRAWING IS THE SOLE PROPERTY OF SIOUX CORP. ANY REPRODUCTION IN PART OR AS A WHOLE WITHOUT WRITTEN PERMISSION OF SIOUX CORP IS PROHIBITED.

DO NOT SCALE DRAWING

UNLESS NOTED:  
 DIMENSIONS IN INCHES. [mm] FOR REFERENCE ONLY.  
 TOLERANCES:  
 LINEAR: ±1/2"  
 ANGULAR: ±2°

DRN	JS 5/26/2021
CHK	JZ 05/26/21
SIZE	A
SCALE	1:25
THIRD-ANGLE PROJECTION	

**SIOUX**  
 SIOUX CORPORATION, ONE SIOUX PLAZA, BERESFORD, SD 57004

SF25 LEG MOUNTED

**GA24077**

REV **A-04** SH 1/1