

MODEL	APPROX. WEIGHT	
	LB	KG
SF20 SKID (DRY)	2400	1100
SF20 SKID (WET)	4150	1900

SUGGESTED MINIMUM CLEARANCES FOR SERVICE ACCESS ARE 48" (1200mm) FOR THE ENDS AND 24" (600mm) ALONG EACH SIDE

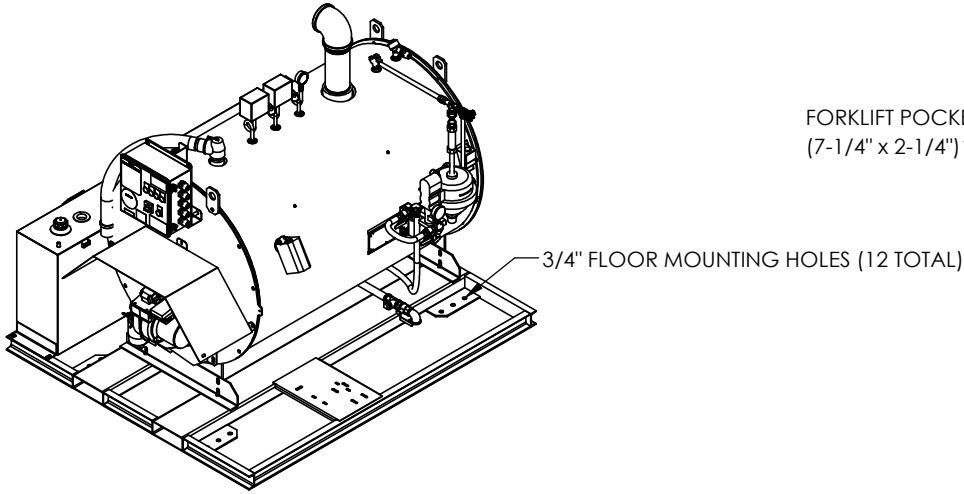

FORKLIFT POCKETS
(7-1/4" x 2-1/4")

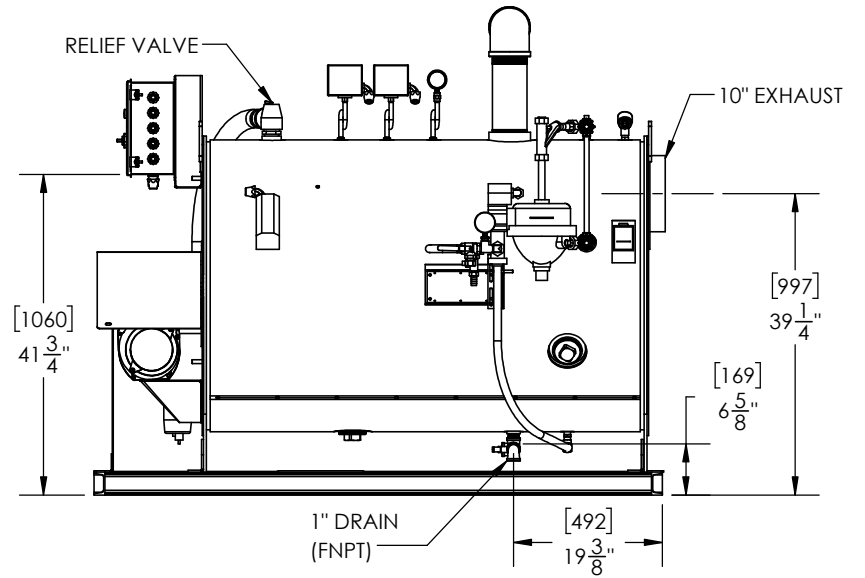
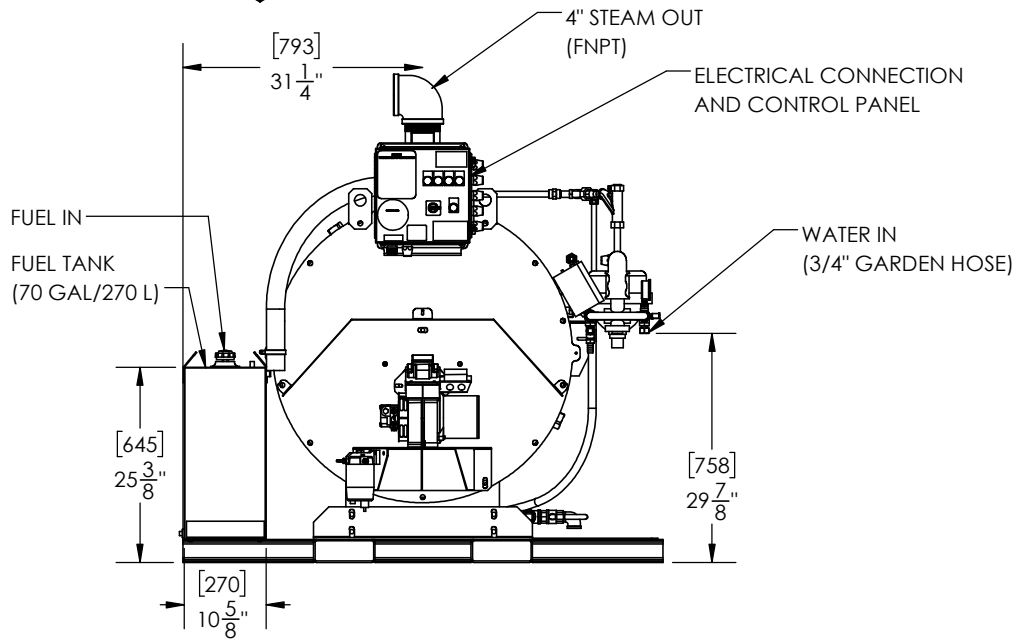
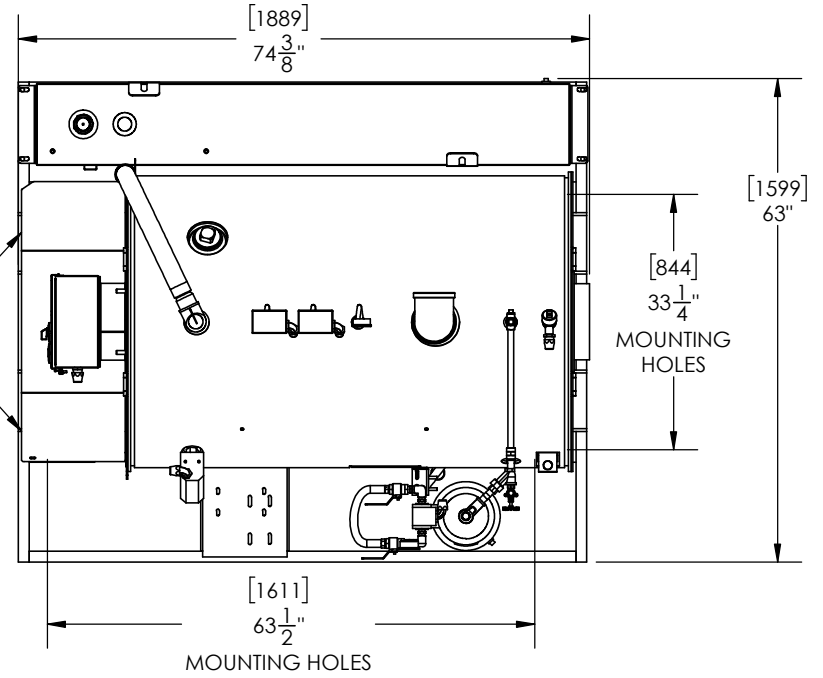

PROPRIETARY AND CONFIDENTIAL
THE INFORMATION CONTAINED IN THIS DRAWING IS THE SOLE PROPERTY OF SIOUX CORP. ANY REPRODUCTION IN PART OR AS A WHOLE WITHOUT WRITTEN PERMISSION OF SIOUX CORP IS PROHIBITED.

UNLESS NOTED:
DIMENSIONS IN INCHES. [mm] FOR REFERENCE ONLY.
TOLERANCES:
LINEAR: ±1/2"
ANGULAR: ±2°

DRN JS 5/26/2021
CHK JZ 05/26/21
SIZE A SCALE 1:25
THIRD-ANGLE PROJECTION

SIOUX
SIOUX CORPORATION, ONE SIOUX PLAZA, BERESFORD, SD 57004

REV.	DESCRIPTION	DATE	BY
A-03	MOVED ENCLOSURE LOCATION	06/06/23	SB
A-02	UPDATED NOTES/CALLOUTS	08/03/21	JS
A-01	ORIGINAL	05/26/21	JZ

DO NOT SCALE DRAWING

GA24081

REV A-03

SH 1/1

DWG NO. GA24081 REV A-03 SHEET 1/1