

MODEL	APPROX. WEIGHT	
	LB	KG
SF20 - DTTM (DRY)	4600	2100
SF20 - DTTM (WET)	7400	3400

WHEELS: STEEL 15" X 6"
 5 BOLT 4.5" B.C.
 TIRES: 205-75-15 C-RATED
 AXLE: TANDEM 3500#
 SPIRNGS: SLIPPER LEAF SPRINGS
 BRAKES: ELECTRIC DRUM
 PLUG: 7-WAY FLAT BLADE
 GVWR: 7000 LBS

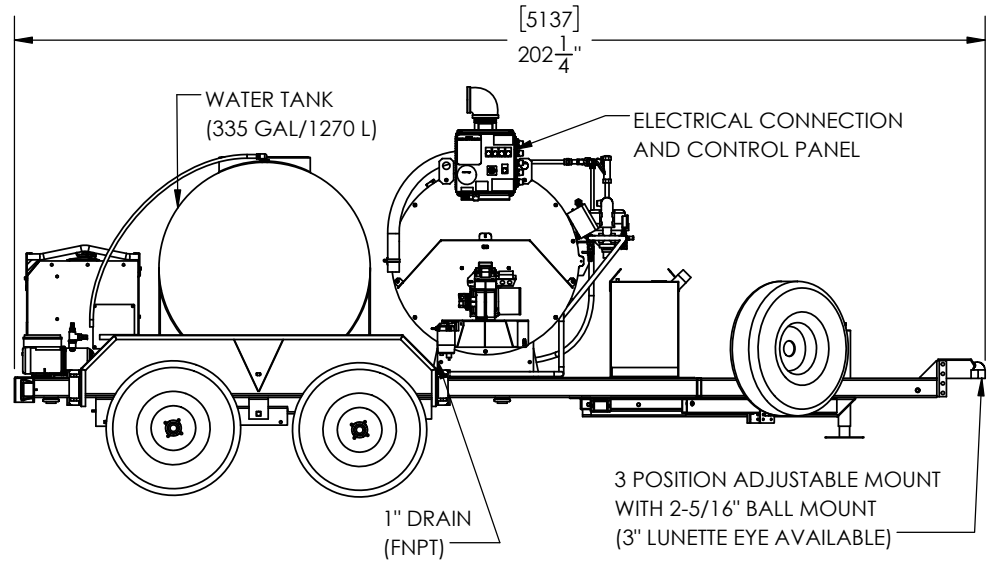
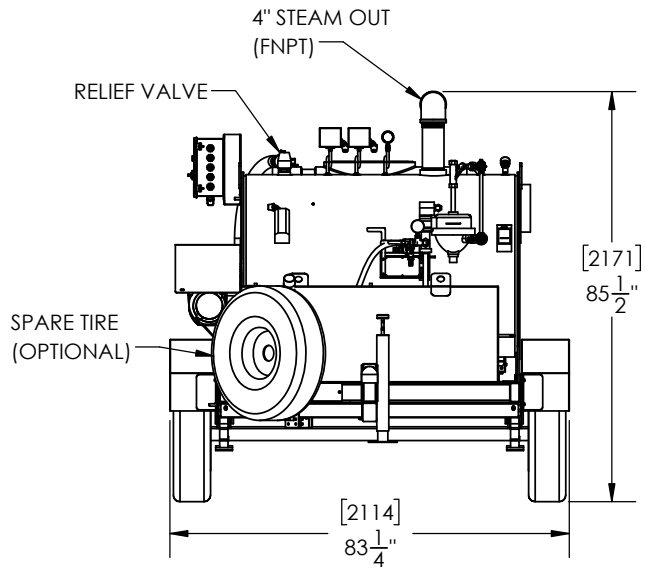
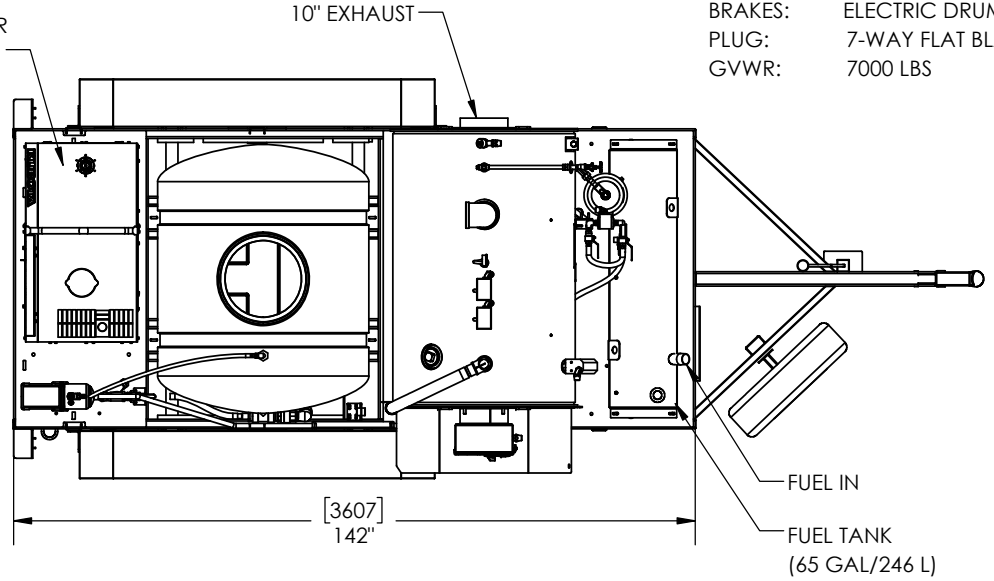
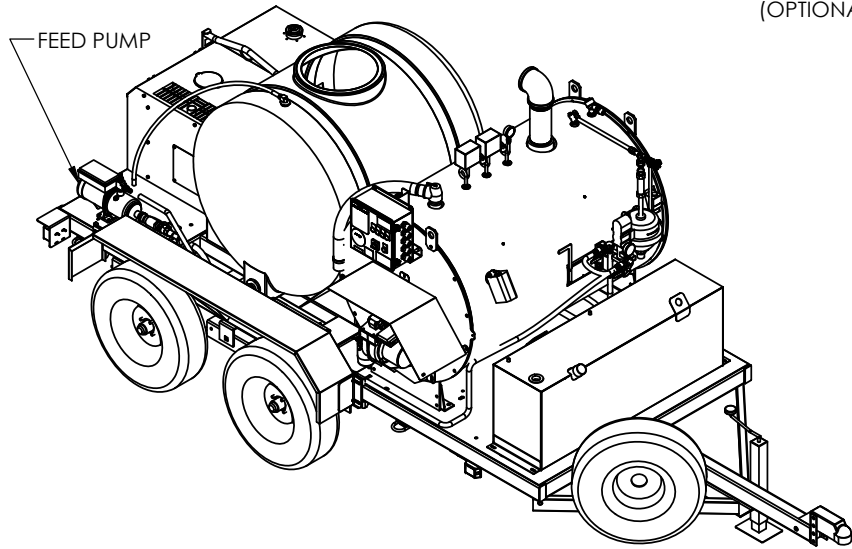

REV.	DESCRIPTION	DATE	BY
A-04	UPDATED NOTES	06/13/23	SB
A-03	MOVED ENCLOSURE LOCATION	06/06/23	SB
A-02	UPDATED NOTES/CALLOUTS	08/04/21	JS
A-01	ORIGINAL	05/27/21	JZ

PROPRIETARY AND CONFIDENTIAL
 THE INFORMATION CONTAINED
 IN THIS DRAWING IS THE SOLE
 PROPERTY OF SIOUX CORP.
 ANY REPRODUCTION IN PART OR
 AS A WHOLE WITHOUT WRITTEN
 PERMISSION OF SIOUX CORP
 IS PROHIBITED.
 DO NOT SCALE DRAWING

UNLESS NOTED:	DRN JS 5/27/2021
DIMENSIONS IN INCHES. [mm] FOR REFERENCE ONLY.	CHK JZ 05/27/21
TOLERANCES	SIZE A SCALE 1:40
LINEAR: ±1/2"	THIRD-ANGLE PROJECTION
ANGULAR: ±2°	

SIOUX
SIOUX CORPORATION, ONE SIOUX PLAZA, BERESFORD, SD 57004

SF20 - DTTM 300 GAL.

GA24093

REV **A-04** SH 1/1

DWG. NO. GA24093 REV A-04 SHEET 1/1