

4		
APPLICABLE MACHINES		
MODEL	APPROX. WEIGHT	
	LB	KG
SF-11E	700	318

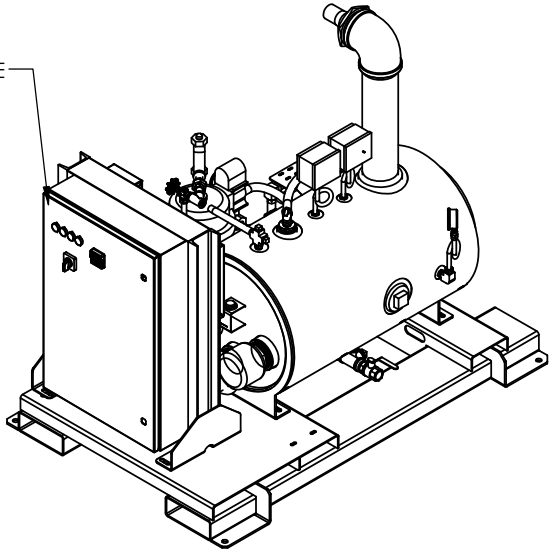

HEATING ELEMENTS
3-38KW SCREW PLUG ELEMENTS

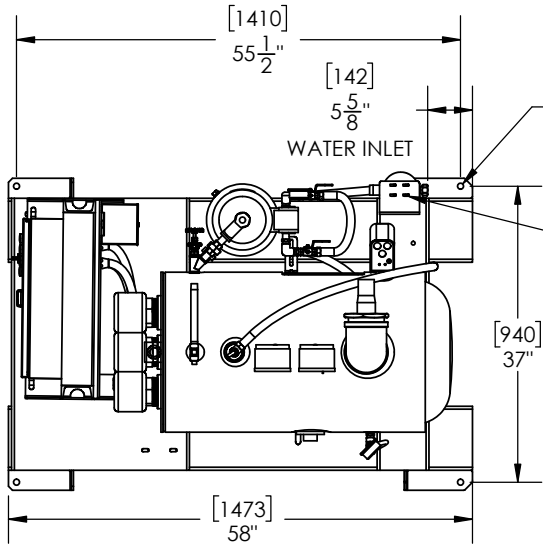
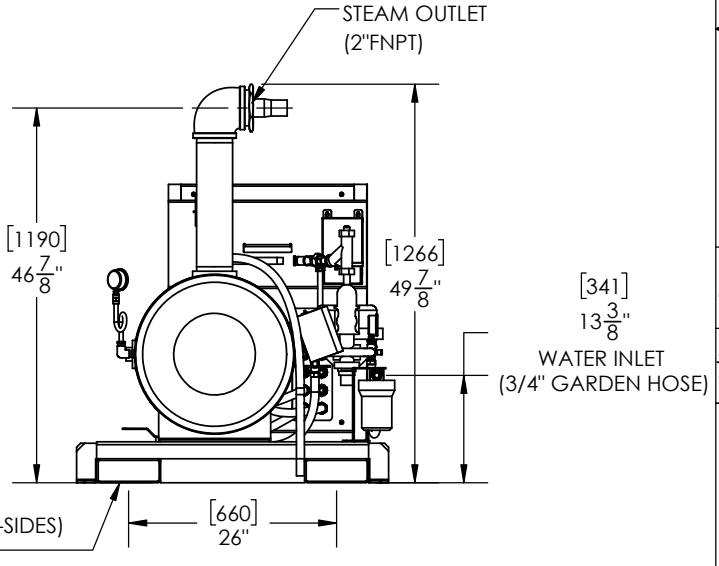
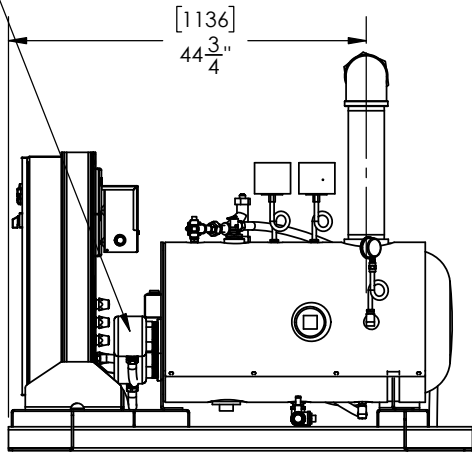
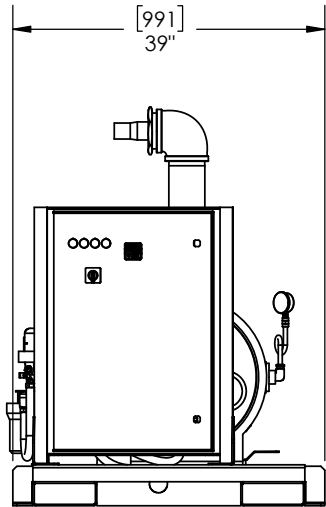

A-04	UPDATED VIEW	05/18/23	LN
A-03	MOVED SF-11	10/07/21	LN
A-02	UPDATED STEAM OUTLET	07/19/21	LN
A-01	ORIGINAL	07/19/21	JZ
REV.	DESCRIPTION	DATE	BY

PROPRIETARY AND CONFIDENTIAL
THE INFORMATION CONTAINED IN THIS DRAWING IS THE SOLE PROPERTY OF SIOUX CORP. ANY REPRODUCTION IN PART OR AS A WHOLE WITHOUT WRITTEN PERMISSION OF SIOUX CORP IS PROHIBITED.
DO NOT SCALE DRAWING

UNLESS NOTED: DIMENSIONS INCHES	DRN LN 7/19/2021
TOLERANCES	CHK JZ 07/19/21
LINEAR: ±.0625 (1/16)	SIZE A SCALE 1:24
ANGULAR: ±2°	THIRD-ANGLE PROJECTION

SIOUX
SIOUX CORPORATION, ONE SIOUX PLAZA, BERESFORD, SD 57004

SF-11E

GA24188

REV	A-04	SH	1/1
-----	------	----	-----

DWG. NO. GA24188 REV. A-04 SHEET 1/1