

| APPLICABLE MACHINES | | |
|---------------------|----------------|-----|
| MODEL | APPROX. WEIGHT | |
| | LB | KG |
| EN5.0H5000-60 | 950 | 432 |

NOTE: CASTERS ADD 8" (20.32cm) TO HEIGHT

TEFC MOTOR

INDUSTRIAL PUMP

WATER OUTLET
(3/8" QUICK COUPLER)

[458]
18"

WATER INLET WITH OPTIONAL HYDROBLEND
(GARDEN HOSE CONNECTION)

[664]
26 1/8"

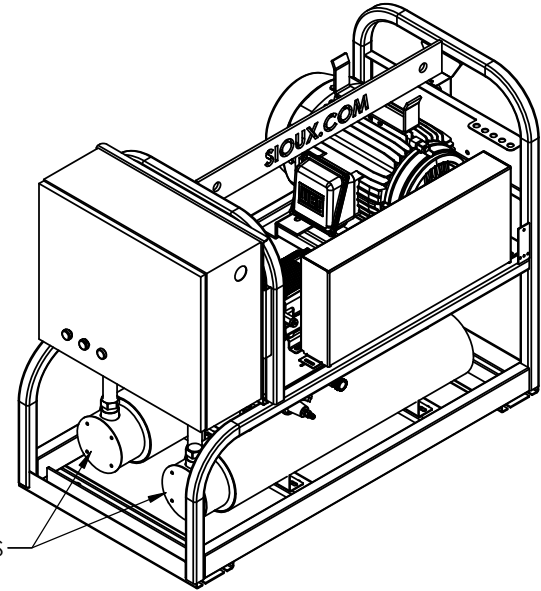

HEATING ELEMENTS

CONTROL ENCLOSURE

[989]
39"

NOTE:
MAINTENANCE REQUIRES 4' MIN. ON ELEMENT
HEAD SIDE AND 2' MIN ON ALL OTHER SIDES

[43] 1 3/4" Ø
[198] 7 7/8" POWER INLET LOCATION

[913]
36"

[649]
25 1/2"

[290] 11 3/8" WATER INLET (WITHOUT HYDRO BLEND)

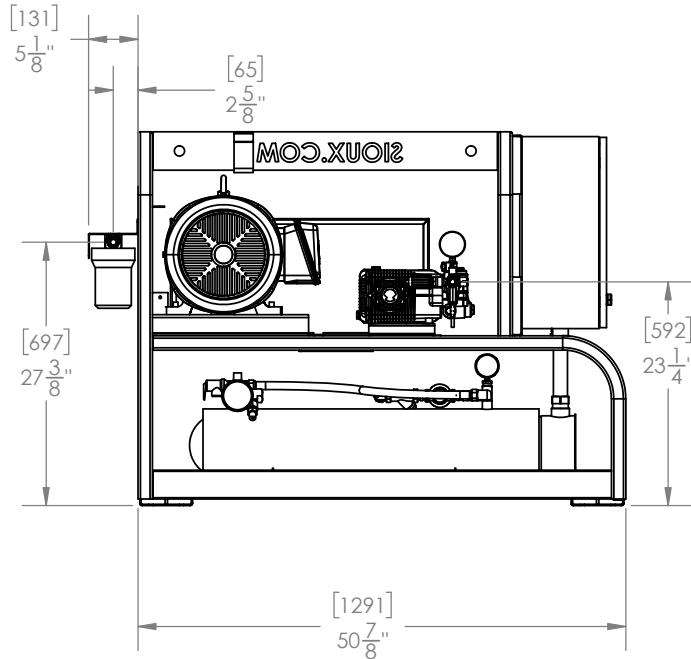

PROPRIETARY AND CONFIDENTIAL

THE INFORMATION CONTAINED IN THIS DRAWING IS THE SOLE PROPERTY OF SIOUX CORP. ANY REPRODUCTION IN PART OR AS A WHOLE WITHOUT WRITTEN PERMISSION OF SIOUX CORP IS PROHIBITED.

UNLESS NOTED: DIMENSIONS IN INCHES. (mm) FOR REFERENCE ONLY.

TOLERANCES
LINEAR: ±1/2"
ANGULAR: ±2°

DRN LN 10/11/22
CHK MW0/11/2022
QC

THIRD-ANGLE PROJECTION

SIOUX CORPORATION

ONE SIOUX PLAZA, BERESFORD, SD 57004

EN5.0H5000-60

GA24966 - 5.0H5000-60

GA24966

REV A-02 SH 1/1

| | | | |
|------|-------------|----------|----|
| A-02 | FIXED VIEW | 10/20/22 | LN |
| A-01 | ORIGINAL | 10/11/22 | MW |
| REV. | DESCRIPTION | DATE | BY |

4

3

1

DWG. NO. GA24966 REV. A-02 SHEET 1/1