

4

3

2

1

APPLICABLE MACHINES		
MODEL	APPROX. WEIGHT	
	LB	KG
WHx1.7PG	2,660	1,207

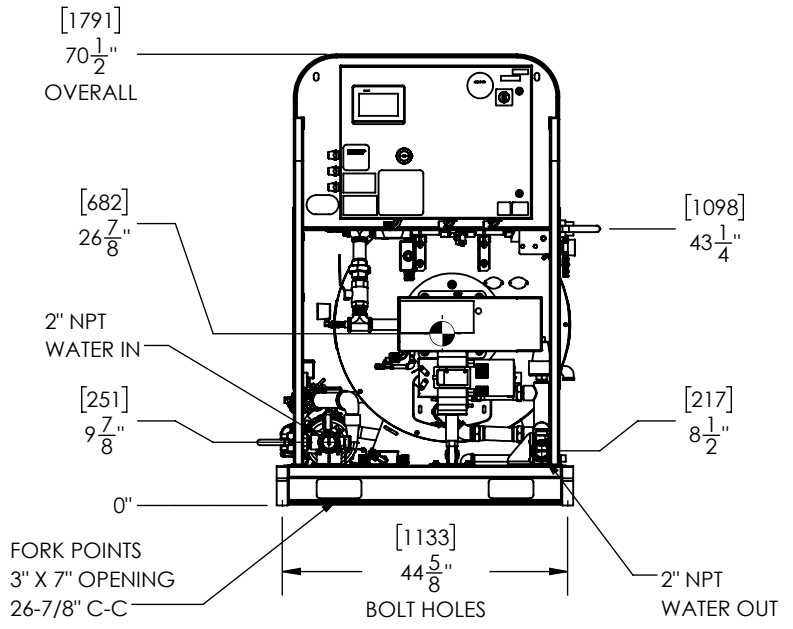
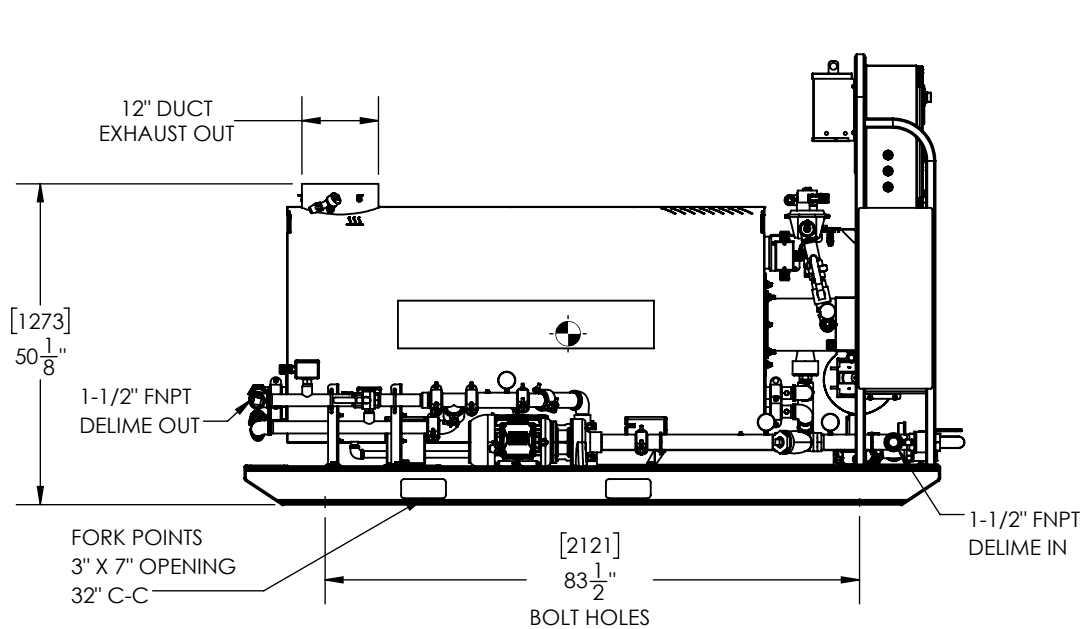
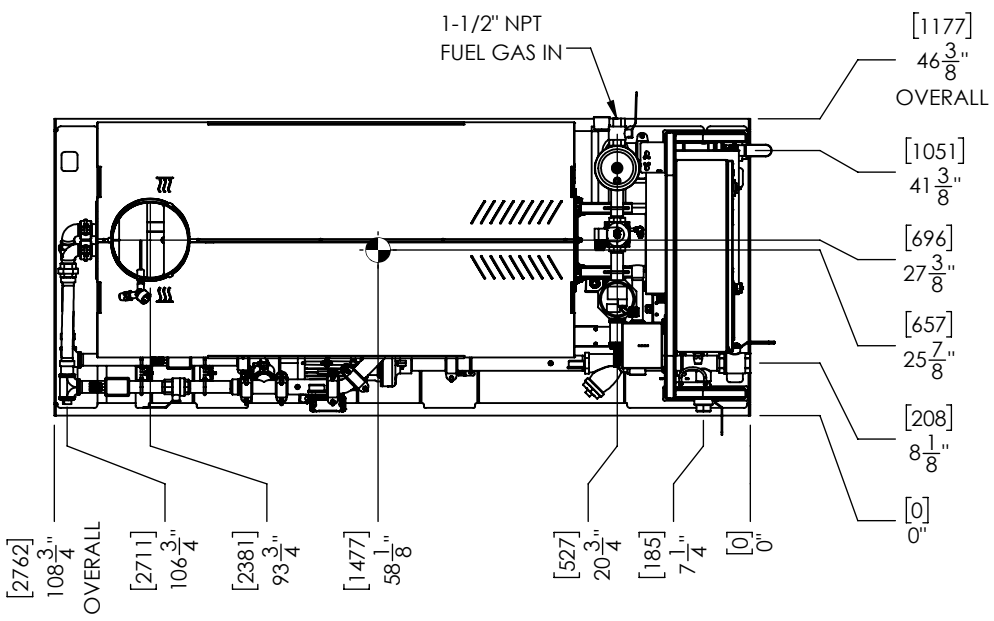

A-04	ECO 00256	03/29/24	JL
A-03	ECO 00243 UPDATES	01/16/24	JL
A-02	UPDATED ENCLOSURE	06/22/23	LN
A-01	APPROVED FOR RELEASE	01/13/23	JL
REV.	DESCRIPTION	DATE	BY

PROPRIETARY AND CONFIDENTIAL
 THE INFORMATION CONTAINED IN THIS DRAWING IS THE SOLE PROPERTY OF SIOUX CORP. ANY REPRODUCTION IN PART OR AS A WHOLE WITHOUT WRITTEN PERMISSION OF SIOUX CORP IS PROHIBITED.

DO NOT SCALE DRAWING

UNLESS NOTED:	DRN LN 01/09/23
DIMENSIONS	CHK JL 01/13/23
INCHES	SIZE A SCALE 1:20
TOLERANCES	THIRD-ANGLE PROJECTION
LINEAR: ±.0625 (1/16)	
ANGULAR: ±2°	

SIOUX
 SIOUX CORPORATION, ONE SIOUX PLAZA, BERESFORD, SD 57004

WHX1.7PG

GA25004 REV **A-04** SH 1/1

4

3

2

1

DWG NO. GA25004
 REV A-04
 SHEET 1/1