

| MODEL | APPROX. WEIGHT | |
|----------|----------------|-------|
| | LB | KG |
| WHx3.0PG | 5,920 | 2,685 |

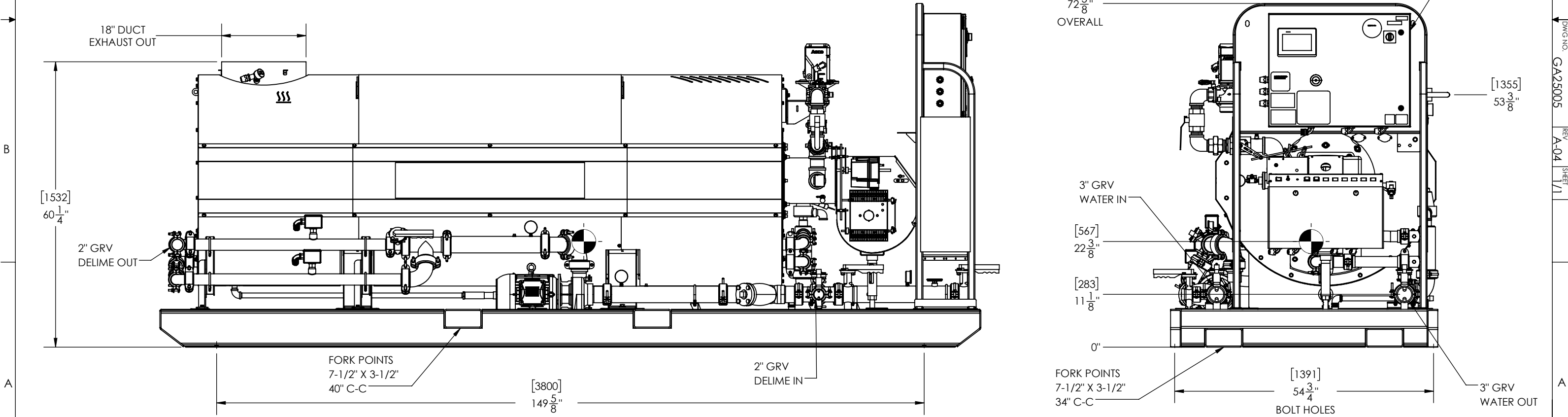
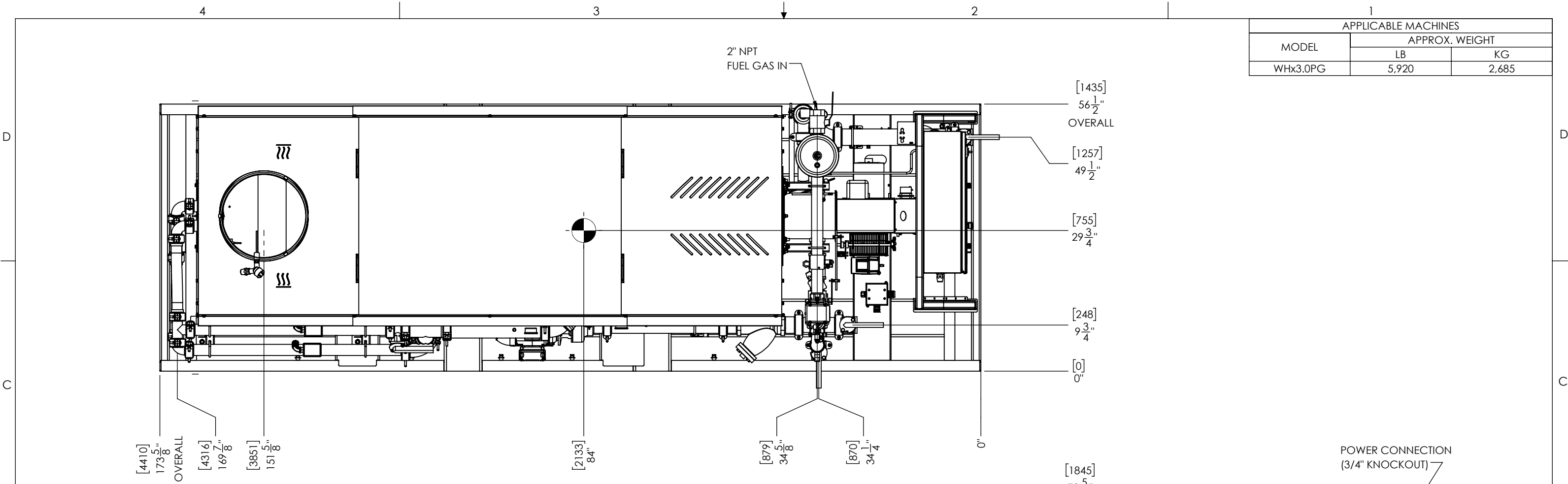

| REV. | DESCRIPTION | DATE | BY |
|------|-------------------|----------|----|
| A-04 | ECO 00256 | 03/28/24 | JL |
| A-03 | ECO 00252 | 01/16/24 | JL |
| A-02 | UPDATED ENCLOSURE | 06/27/23 | LN |
| A-01 | ORIGINAL | 01/13/23 | MW |

| | | |
|---|---|------------------------|
| PROPRIETARY AND CONFIDENTIAL THE INFORMATION CONTAINED IN THIS DRAWING IS THE SOLE PROPERTY OF SIOUX CORP. ANY REPRODUCTION IN PART OR AS A WHOLE WITHOUT WRITTEN PERMISSION OF SIOUX CORP IS PROHIBITED. DO NOT SCALE DRAWING | UNLESS NOTED: | DRN LN 01/06/23 |
| | DIMENSIONS IN INCHES, [mm] FOR REFERENCE ONLY | CHK MW 01/13/23 |
| | TOLERANCES | SIZE B SCALE 1:20 |
| | LINEAR: ±[13] 1/2 ANGULAR: ±2° | THIRD-ANGLE PROJECTION |

| | | |
|---|----------|--------|
| SIOUX | | |
| SIOUX CORPORATION, ONE SIOUX PLAZA, BERESFORD, SD 57004 | | |
| WHX3.0PG | | |
| GA25005 | REV A-04 | SH 1/1 |

DWG. NO. GA25005
 REV. A-04
 SHEET 1/1