

APPLICABLE MACHINES		
MODEL	APPROX. WEIGHT	
	LB	KG
M-415	550	250

NOTE 1: M-415 IS OFFERED IN 12 VOLT DC AND 120 VOLT AC.

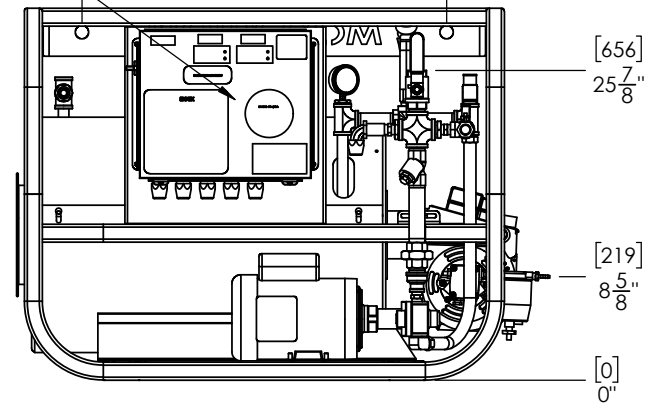
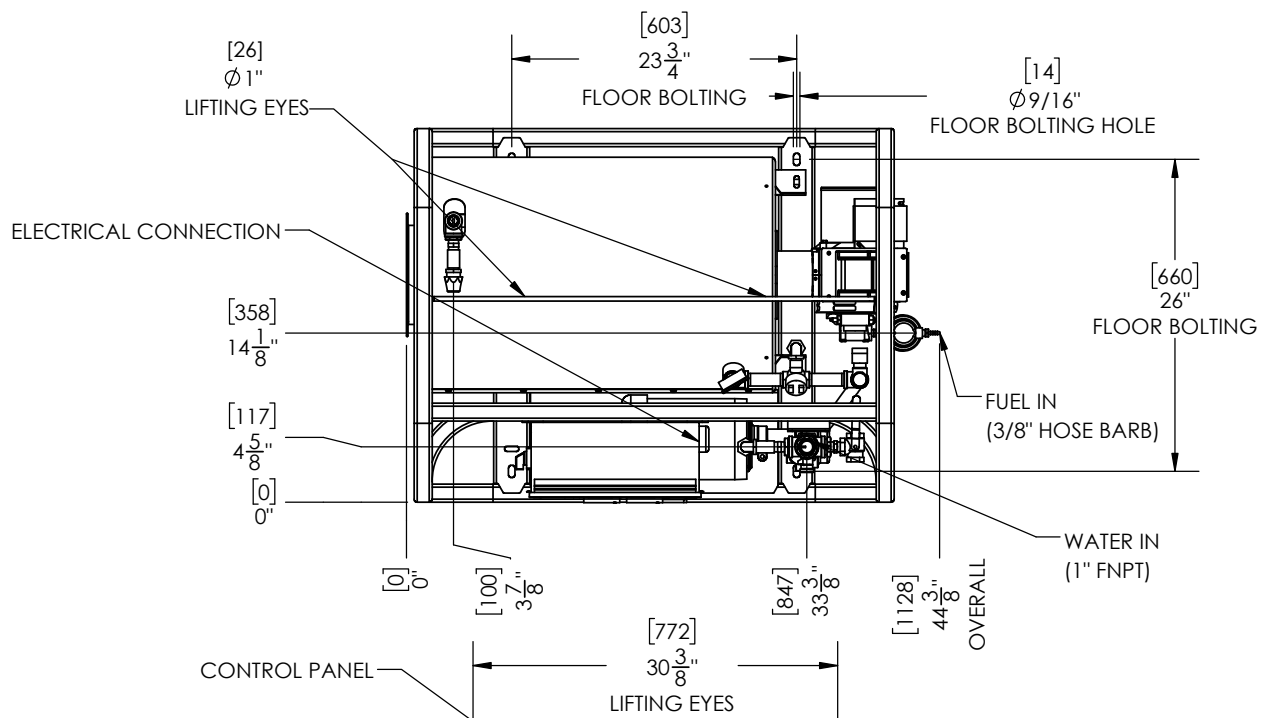
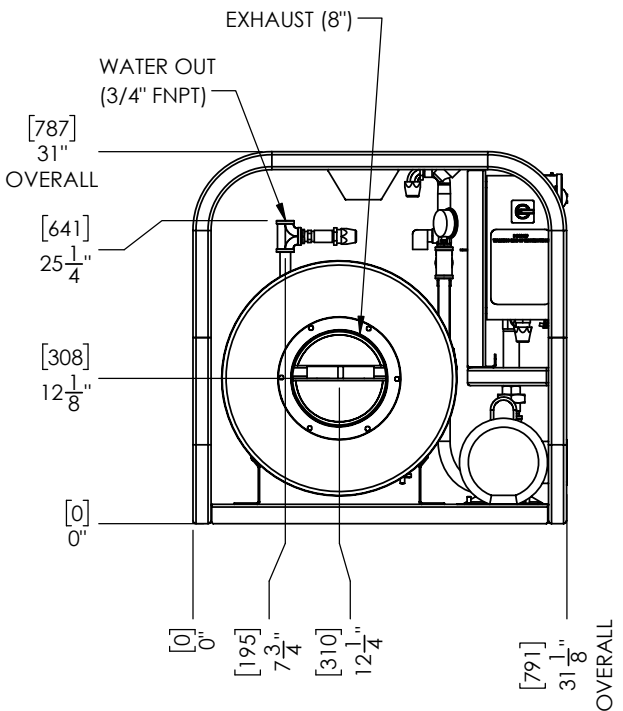

REV.	DESCRIPTION	DATE	BY
A-04	ADDED CALLOUTS/DIM.	06/02/21	TO
A-03	ADDED CALL OUTS/DIM.	06/02/21	TO
A-01	APPROVED FOR RELEASE	06/01/21	JL

PROPRIETARY COPYRIGHT AND CONFIDENTIAL
 Copyright © 6/4/2021 SIOUX CORPORATION.
 The information contained in this drawing is the sole property of Sioux Corp. This information is subject to recall at any time and is not to be used in any way detrimental to Sioux's interests. Any reproduction in part or as a whole without written permission of Sioux Corp is prohibited. Use of material is subject to the terms of website use listed at www.siuox.com

UNLESS NOTED:
 DIMENSIONS IN INCHES. [mm] FOR REFERENCE ONLY.
 TOLERANCES
 LINEAR: ±1/2"
 ANGULAR: ±2°

DRN TO 6/1/2021
 CHK JL 6/1/2021
 QC

SIOUX CORPORATION
 ONE SIOUX PLAZA, BERESFORD, SD 57004

M-415 OIL

THIRD-ANGLE PROJECTION

SIZE A SCALE 1:16 FILE GA24108 - M-415 OIL

GA24108

REV A-04 SH 1/1

DWG NO. GA24108
 REV A-04
 SHEET 1/1