

MODEL	APPROX. WEIGHT	
	LB	KG
SF20 ENC (DRY)	7100	3250
SF20 ENC (WET)	11850	5350

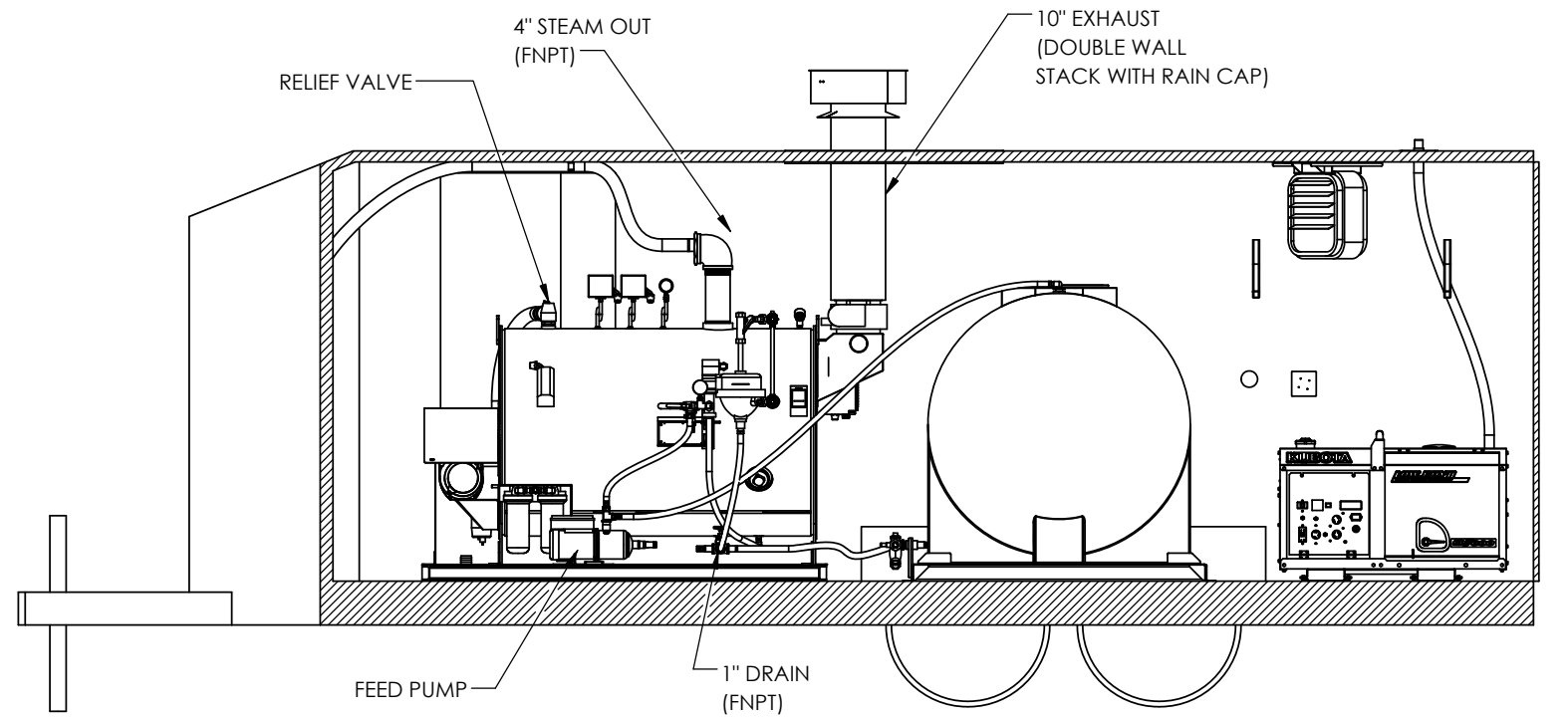

SECTION B-B  
SCALE 1 : 35

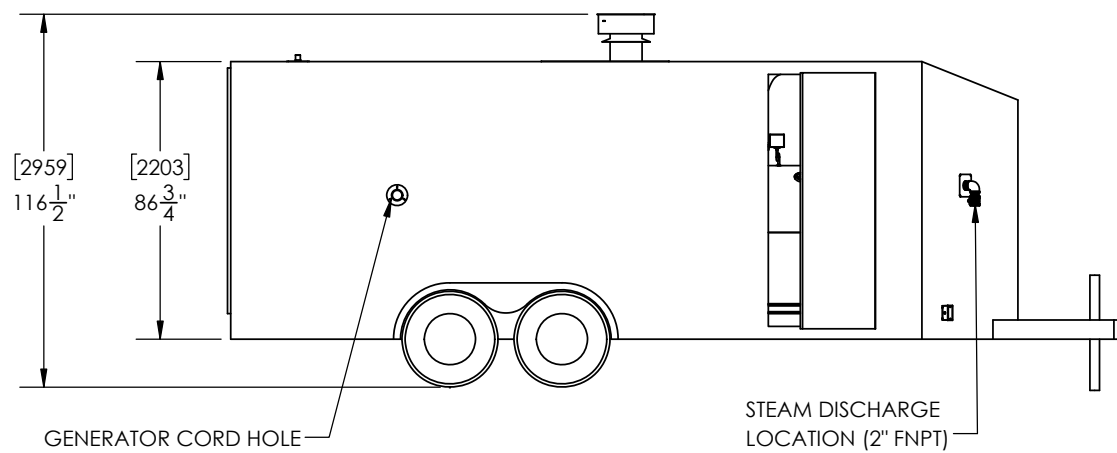
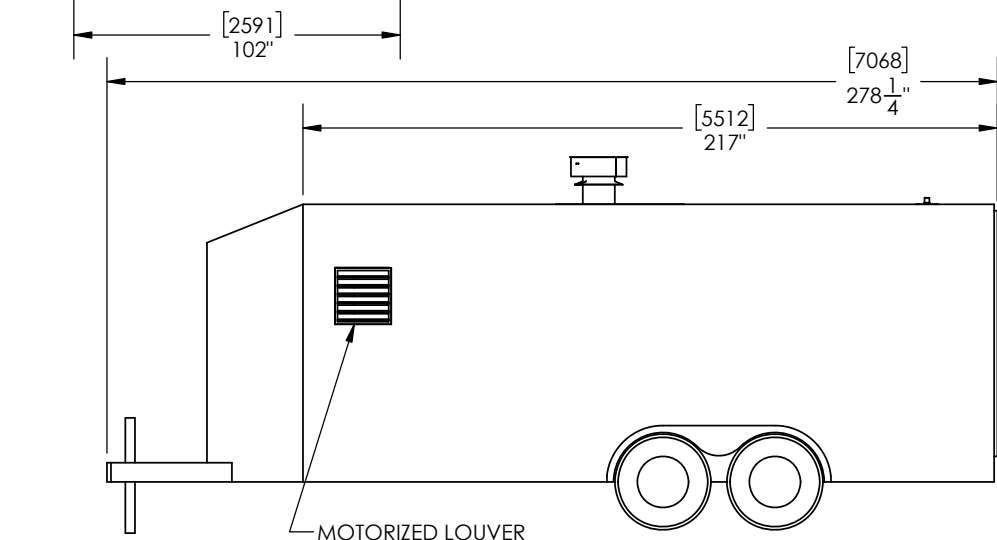
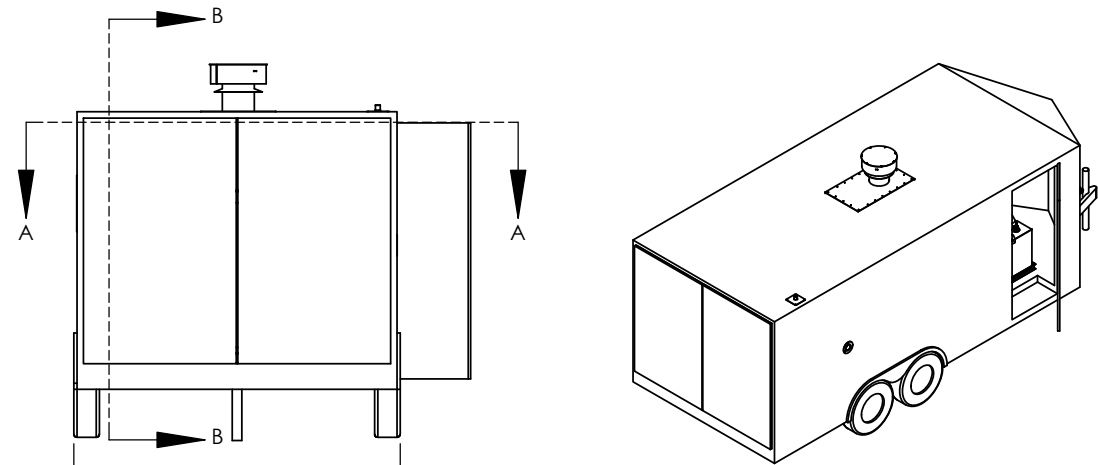
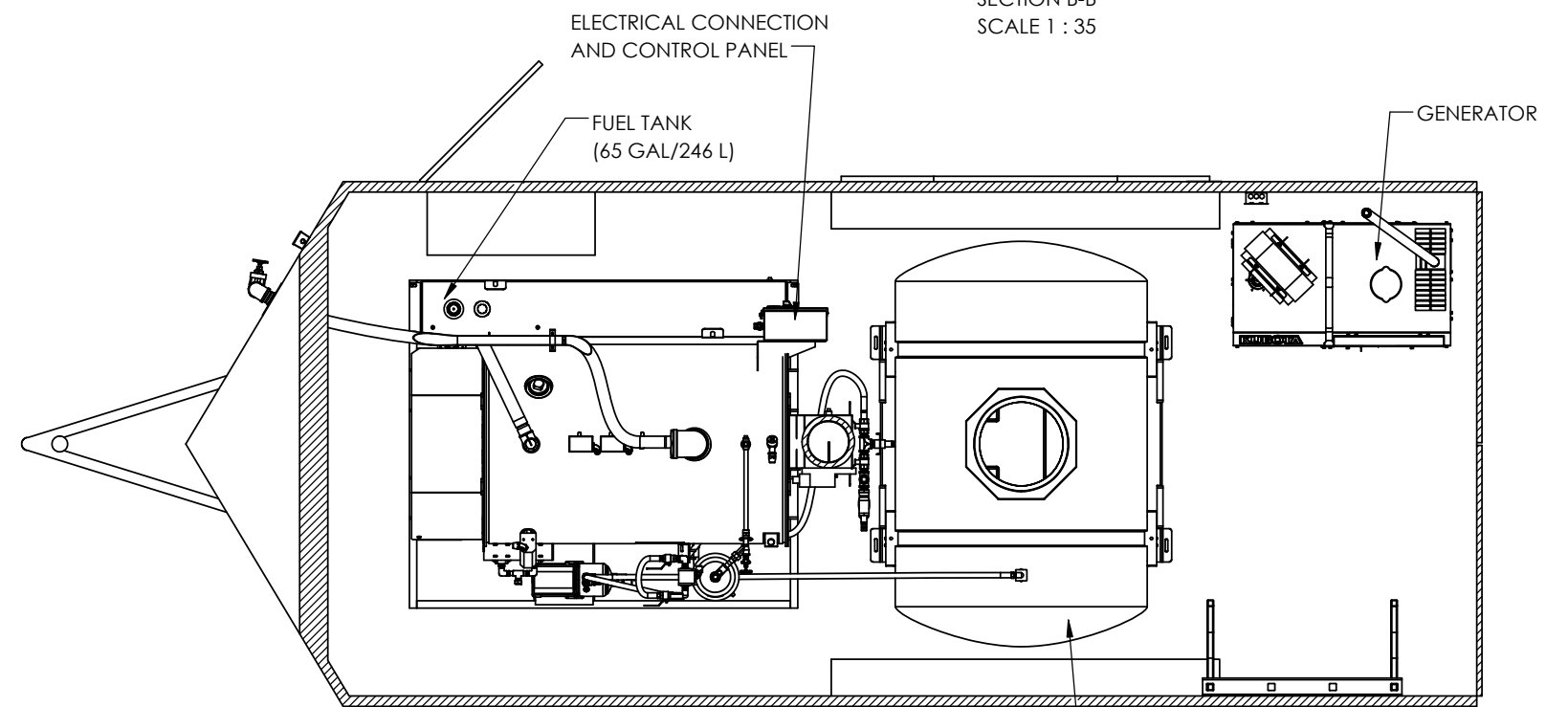

SECTION A-A  
SCALE 1 : 35

REV.	DESCRIPTION	DATE	BY
A-03	FIXED ENCLOSURE	02/01/22	LN
A-02	UPDATED NOTES/CALLOUTS	08/05/21	JS
A-01	ORIGINAL	07/30/20	JL

**PROPRIETARY COPYRIGHT AND CONFIDENTIAL**  
Copyright © 2/1/2022 SIOUX CORPORATION.  
The information contained in this drawing is the sole property of Sioux Corp. This information is subject to recall at any time and is not to be used in any way detrimental to Sioux's interests. Any reproduction in part or as a whole without written permission of Sioux Corp is prohibited. Use of material is subject to the terms of website use listed at [www.siuox.com](http://www.siuox.com)

UNLESS NOTED:  
DIMENSIONS IN INCHES, [mm] FOR REFERENCE ONLY  
TOLERANCES  
LINEAR: ±[13] 1/2  
ANGULAR: ±2°

DRN LN 7/30/2020  
CHK JL 7/30/2020  
QC  
THIRD-ANGLE PROJECTION

<b>SIOUX CORPORATION</b> ONE SIOUX PLAZA, BERESFORD, SD 57004	
SF20D-ENC	
SIZE B	SCALE 1:60
FILE	GA23587
REV A-03	SH 1/1

DWG NO. GA23587 REV A-03 SHEET 1/1