

MODEL	APPROX. WEIGHT	
	LB	KG
SF50G-TM (DRY)	6150	2800
SF50G-TM (WET)	8900	4050

WHEELS: STEEL 15" X 6"
 6 BOLT 5.5" B.C.
 TIRES: 225-75-15 C-RATED
 AXLE: DOUBLE 5200#
 SPIRINGS: SLIPPER LEAF SPRINGS
 BRAKES: ELECTRIC DRUM
 PLUG: 7-WAY FLAT BLADE
 GVWR: 10400 LBS

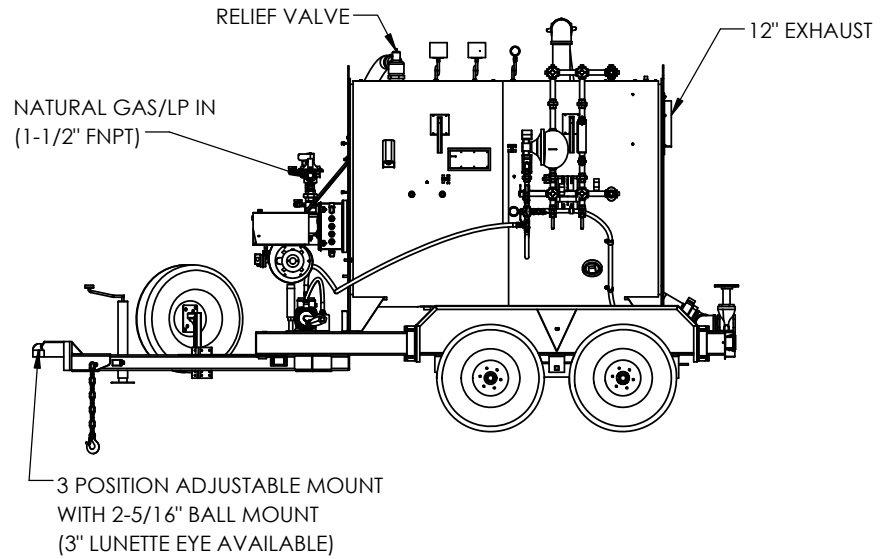
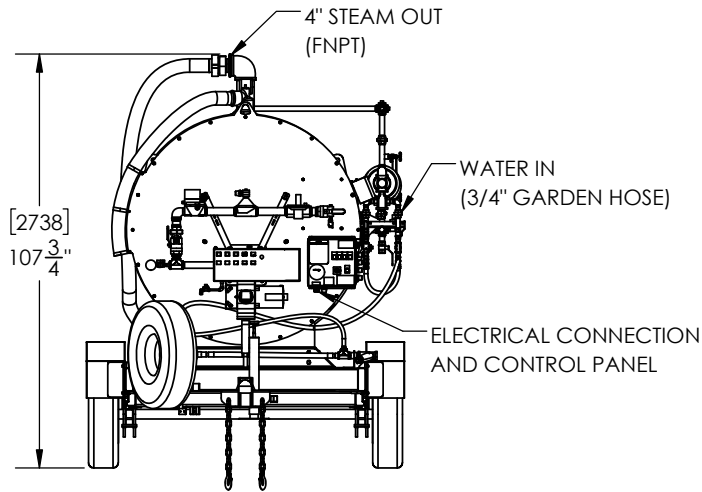
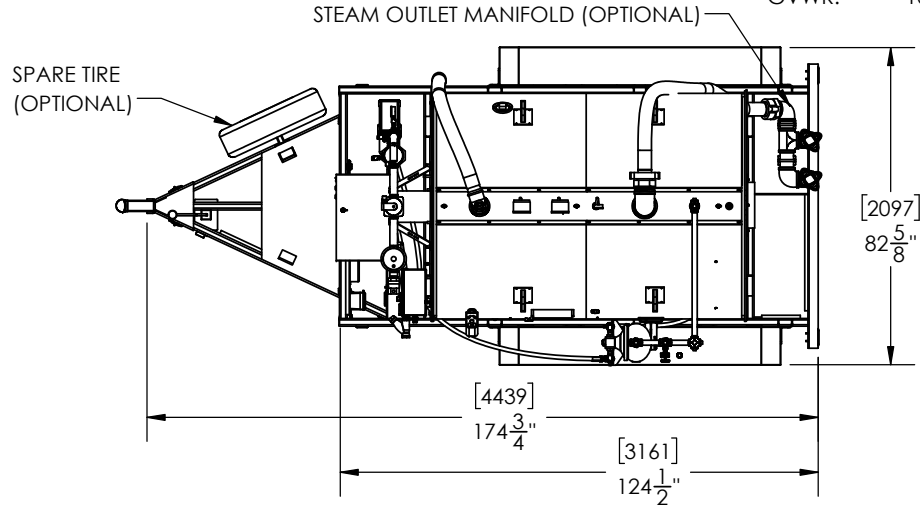
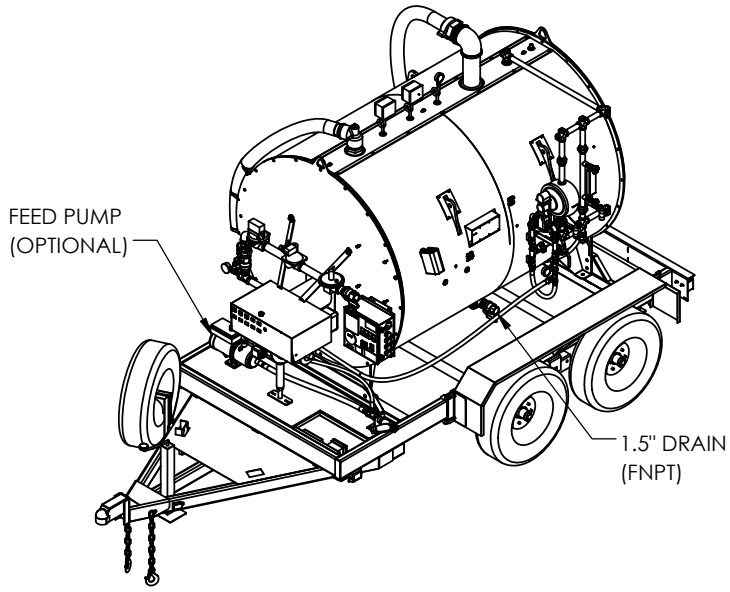

PROPRIETARY AND CONFIDENTIAL

THE INFORMATION CONTAINED IN THIS DRAWING IS THE SOLE PROPERTY OF SIOUX CORP. ANY REPRODUCTION IN PART OR AS A WHOLE WITHOUT WRITTEN PERMISSION OF SIOUX CORP IS PROHIBITED.

UNLESS NOTED: DRN JS 5/27/2021
 DIMENSIONS IN INCHES. (mm) FOR REFERENCE ONLY. CHK JZ 5/27/2021
 TOLERANCES: THIRD-ANGLE PROJECTION
 LINEAR: ±1/2"
 ANGULAR: ±2°

SIOUX CORPORATION
 ONE SIOUX PLAZA, BERESFORD, SD 57004

SF50G-TM

A-02	UPDATED NOTES/CALLOUTS	08/02/21	JS
A-01	ORIGINAL	05/27/21	JZ
REV.	DESCRIPTION	DATE	BY

DO NOT SCALE DRAWING

SIZE	A	SCALE	1:50	FILE	GA23794
REV	A-02	SH	1/1		

DWG. NO. GA23794
 REV. A-02
 SHEET 1/1