

MODEL	APPROX. WEIGHT	
	LB	KG
SF50-ENC (DRY)	14800	6750
SF50-ENC (WET)	20400	9300

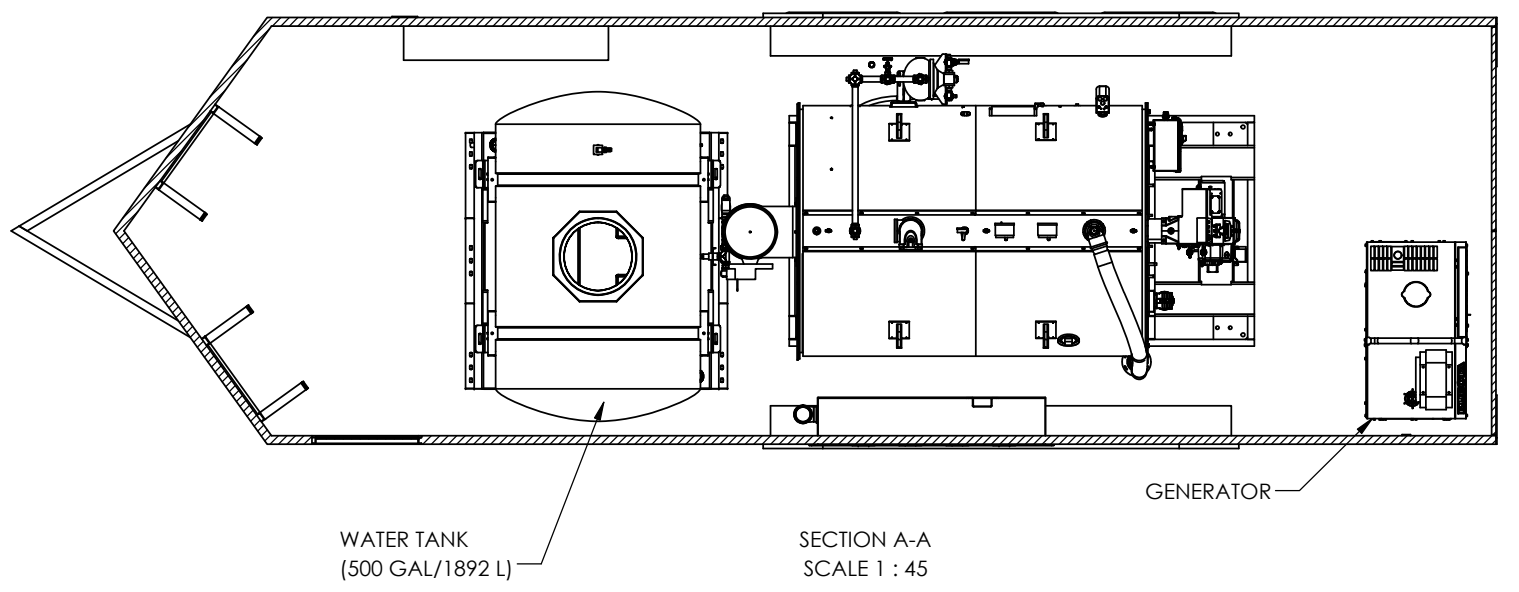
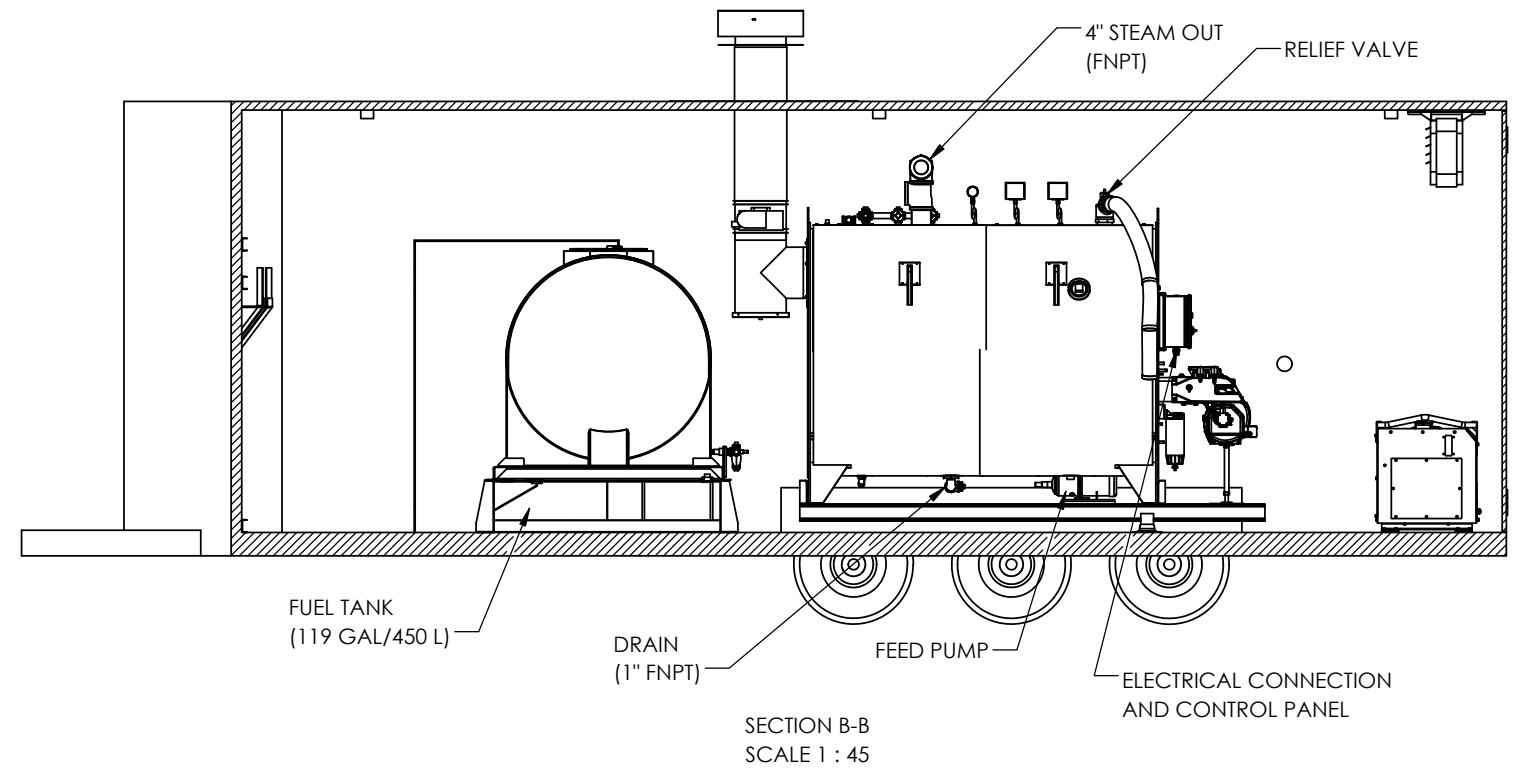
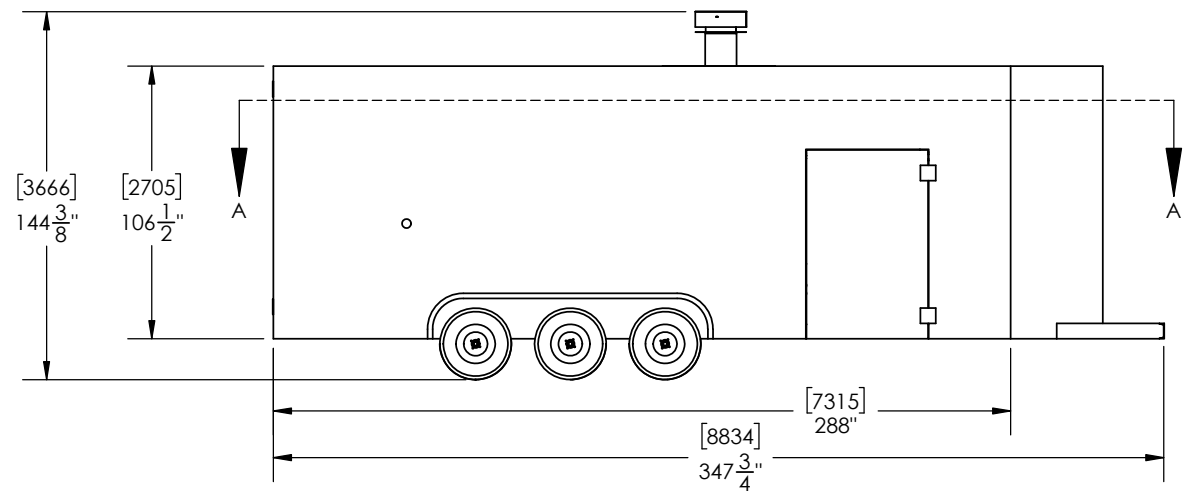
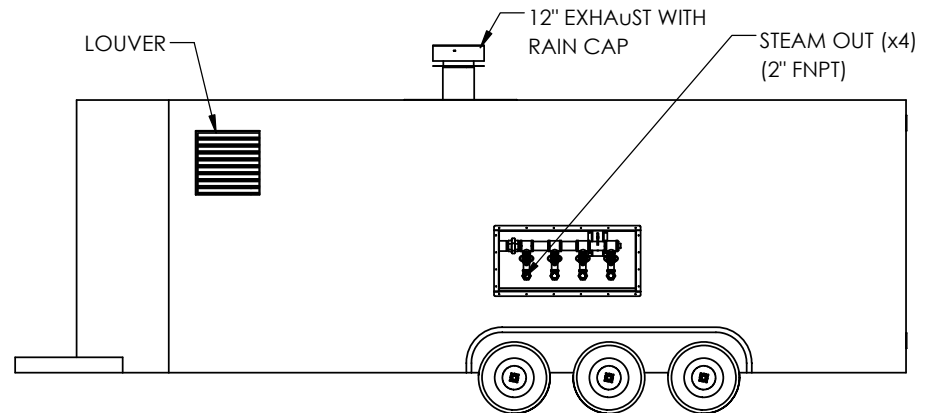
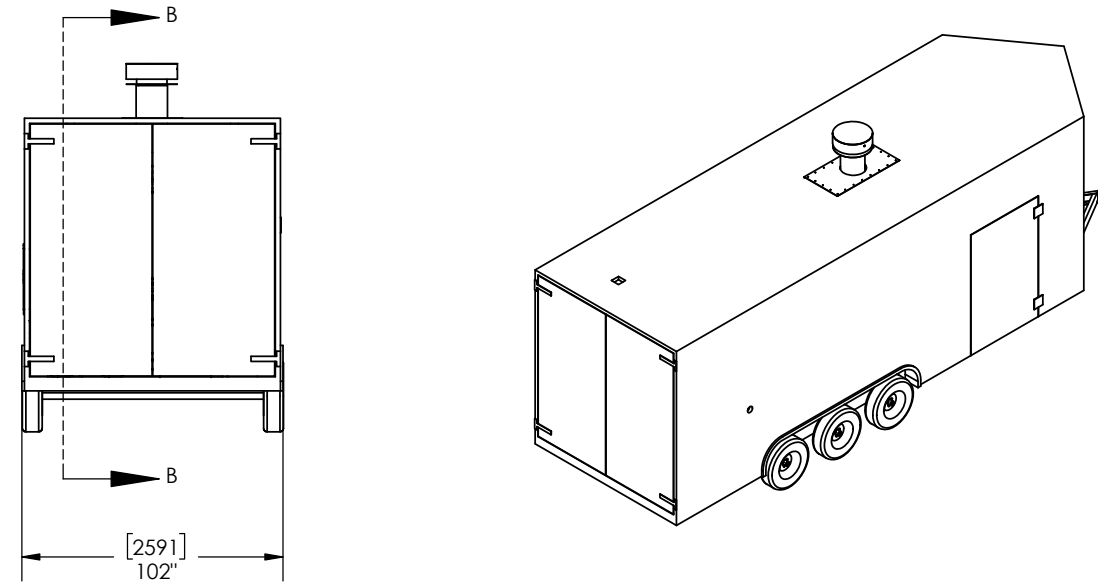

REV.	DESCRIPTION	DATE	BY
A-03	UPDATED NOTES/CALLOUTS	08/06/21	JS
A-02	ADDED TONGUE WEIGHT	03/08/19	LN
A-01	ORIGINAL	03/06/19	DB

PROPRIETARY COPYRIGHT AND CONFIDENTIAL
 Copyright © 8/10/2021 SIOUX CORPORATION.
 The information contained in this drawing is the sole property of Sioux Corp. This information is subject to recall at any time and is not to be used in any way detrimental to Sioux's interests. Any reproduction in part or as a whole without written permission of Sioux Corp is prohibited. Use of material is subject to the terms of website use listed at www.siuox.com

UNLESS NOTED:	DRN LN	3/6/2019	SIOUX CORPORATION ONE SIOUX PLAZA, BERESFORD, SD 57004
DIMENSIONS IN INCHES, [mm] FOR REFERENCE ONLY	CHK DB	3/6/2019	
TOLERANCES	SF50-ENC		
THIRD-ANGLE PROJECTION	SIZE B	SCALE 1:75	FILE GA22734 SF-50 ENCLOSED TRAILER
LINEAR: ±[13] 1/2	GA22734		
ANGULAR: ±2°			

DWG NO. GA22734 REV A-03 SHEET 1/1